The background of the cover features architectural drawings. At the top, there are three cross-sections of concrete masonry walls and window openings, showing reinforcement and joint details. On the right side, there is a partial floor plan showing a grid of walls and columns. The entire background is overlaid with a faint, light-colored grid pattern. The title text is centered within a white rectangular box.

THE GUIDE TO  
**Concrete Masonry**  
**Residential Construction**  
*in HIGH-WIND AREAS*

**Recommendations for Design and Construction**

June 30, 1997

# TABLE OF CONTENTS

## GUIDE TO CONCRETE MASONRY RESIDENTIAL CONSTRUCTION IN HIGH WIND AREAS

- 1.1 Table of Contents - General
- 1.2 Introduction
- 1.3 Definitions
- 1.4 Definitions - Continued
- 1.5 **How To Use This Guide**
- 1.6 **How To Use This Guide - Continued**
- 1.7 **How To Use This Guide - Continued**
- 1.8 Building Shapes
- 1.9 Key Example Plan
- 1.10 Key Example Elevations
- 1.11 Typical Wall Section
  
- 90.1 Table of Contents - 90 mph Design Wind Velocity
- 90.2 Vertical Reinforcement Details
- 90.3 Vertical Reinforcement Spacing
- 90.4 Gable Endwall Vertical Reinforcement
- 90.5 Shearwall Design Notes
- 90.6 Shearwall Proportioning Example
- 90.7 Shearwall Design Table
- 90.8 Lintel Types
- 90.9 Lintel Types - Continued
- 90.10 Lintel Schedule
- 90.11 Gable Endwall Details
- 90.12 Interior Bearing Wall Detail
- 90.13 Interior Bearing Wall Openings
- 90.14 Roof Truss Anchor
- 90.15 Entry Condition Details
- 90.16 Valley / Hip Detail
- 90.17 Roof Sheathing Attachment
- 90.18 Alternate Gable End Detail
- 90.19 Alternate Gable End Detail - Cont.
- 90.20 Alternate Gable End Detail - Cont.
  
- 100.1 Table of Contents - 100 mph Design Wind Velocity
- 100.2 Vertical Reinforcement Details
- 100.3 Vertical Reinforcement Spacing
- 100.4 Gable Endwall Vertical Reinforcement
- 100.5 Shearwall Design Notes
- 100.6 Shearwall Proportioning Example
- 100.7 Shearwall Design Table
- 100.8 Lintel Types
- 100.9 Lintel Types - Continued
- 100.10 Lintel Schedule
- 100.11 Gable Endwall Details
- 100.12 Interior Bearing Wall Detail
- 100.13 Interior Bearing Wall Openings
- 100.14 Roof Truss Anchor
- 100.15 Entry Condition Details
- 100.16 Valley / Hip Detail
- 100.17 Roof Sheathing Attachment
- 100.18 Alternate Gable End Detail
- 100.19 Alternate Gable End Detail - Cont.
- 100.20 Alternate Gable End Detail - Cont.
  
- 110.1 Table of Contents - 110 mph Design Wind Velocity
- 110.2 Vertical Reinforcement Details
- 110.3 Vertical Reinforcement Spacing
- 110.4 Gable Endwall Vertical Reinforcement
- 110.5 Shearwall Design Notes
- 110.6 Shearwall Proportioning Example
- 110.7 Shearwall Design Table
- 110.8 Lintel Types
- 110.9 Lintel Types - Continued
- 110.10 Lintel Schedule
- 110.11 Gable Endwall Details
- 110.12 Interior Bearing Wall Detail
- 110.13 Interior Bearing Wall Openings
- 110.14 Roof Truss Anchor
- 110.15 Entry Condition Details
- 110.16 Valley / Hip Detail
- 110.17 Roof Sheathing Attachment
- 110.18 Alternate Gable End Detail
- 110.19 Alternate Gable End Detail - Cont.
- 110.20 Alternate Gable End Detail - Cont.

The purpose of this Guide is to simplify the construction and design of concrete masonry single story buildings in high wind areas where fastest-mile design wind velocities reach 90, 100 and 110 miles per hour. THIS GUIDE IS IN COMPLIANCE WITH THE 1994 EDITION WITH 1996 REVISIONS AND 1997 EDITION, CHAPTER 16 OF THE STANDARD BUILDING CODE ON WIND AND LIVE LOADS. The concrete masonry was designed in accordance with the Building Code Requirements for Masonry Structures (ACI 530-95).

The provisions of this Guide are directed toward ensuring structural integrity for resisting wind loads. They do not address requirements for earthquake or flood loads, or any other more stringent design considerations. Where specific construction requirements are not given, appropriate requirements of the Standard Building Code shall prevail.

For buildings outside the range of design parameters, design load criteria, and materials and methods of construction outlined in this Guide, the design shall be structurally reviewed for wind resistance by a registered engineer or architect when required by the Building Official.

Individual elements of a building not in strict compliance with, or addressed by this Guide may be engineered without requiring engineering for the entire building. Elements which maintain the structural integrity of the building envelope shall comply with Section 1606 of the Standard Building Code. Windows and doors shall be designed for Components and Cladding loads of SBC 1606.

Elements and assemblies not specifically addressed by this Guide shall be:

1. (except for clay brick), in conformance with SBCCI's "Standard for Hurricane Resistant Residential Construction", SSTD 10 for buildings within the same parameters as this document including size, height and roof slope, or
2. designed in accordance with Section 1606 of the Standard Building Code.

Roofs, ceilings and suspended floors are designed as diaphragms to receive lateral loads from exterior walls (assuming the wind blowing from any direction) and to transfer these loads to diaphragm edges where they will be resisted by shearwalls.

Exterior walls are designed to resist wind forces and transfer the lateral loads to diaphragms and to the ground. Exterior walls and foundations are designed to restrain uplift loads received from the roof by means of connected dead loads. Deflection criteria are based upon those given in the Standard Building Code.

Wind load velocity areas where design winds can exceed 110 miles per hour and multi-story construction are beyond the scope of this manual. Also, it is not the intention of this manual to instruct on proper roof framing techniques. Foundation systems need to be provided that are capable of resisting the applied loads and with consideration for subsurface conditions. Foundations shall be in accordance with SSTD 10 or engineered. Additional connections may be required to satisfy the requirements of finishes, waterproofing, and non-structural concerns.

THE INFORMATION IN THIS MANUAL HAS BEEN DESIGNED WITH DUE CARE AND OFFERED FOR THE PURPOSE OF PROVIDING USEFUL INFORMATION TO ARCHITECTS, BUILDERS, DESIGNERS, LOCAL AUTHORITIES, INSTRUCTORS AND OTHER INTERESTED PARTIES IN SIMPLIFIED DESIGN OF SINGLE STORY BUILDINGS WHICH MEET APPLICABLE BUILDING CODES. THE AUTHORS AND SPONSORS DO NOT, HOWEVER, ASSUME ANY RESPONSIBILITY FOR ERRORS OR OMISSIONS IN THE GUIDE, NOR FOR DESIGNS, PLANS OR STRUCTURES PREPARED FROM IT. THE GUIDE IS BASED UPON THE IMPLEMENTATION OF THE DETAILS SHOWN BEING CARRIED OUT IN ACCORDANCE WITH ALL APPLICABLE CODES, STANDARDS, GUIDES, AND GOOD QUALITY WORKMANSHIP.

THE FOLLOWING DEFINITIONS DESCRIBE SOME OF THE TERMINOLOGY USED IN THIS MANUAL:

**BLOCKING:**

SOLID WOOD BLOCK WHICH PROVIDES LATERAL SUPPORT AS IN BRIDGING, AND/OR EDGE SUPPORTING FOR SHEATHING.

**BOND BEAM BLOCK:**

A STANDARD BLOCK UNIT MANUFACTURED WITH  $2\frac{3}{4}$ " RECESS FOR HIGH PLACEMENT OF REINFORCEMENT TO RESIST UPLIFT FORCES.

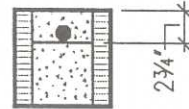

**CEILING HEIGHT:**

NOMINAL DISTANCE MEASURED AT THE SIDEWALL BETWEEN TOP OF FLOOR AND BOTTOM SURFACE OF CEILING ABOVE THAT IS DIRECTLY ATTACHED TO ROOF FRAMING SYSTEM.

**DIAPHRAGM:**

A HORIZONTAL STRUCTURAL UNIT COMPOSED OF SHEATHING, FRAMING MEMBERS, AND PERIMETER MEMBERS WHICH ACT AS A DEEP THIN BEAM TO TRANSFER LATERAL FORCES TO VERTICAL RESISTING ELEMENTS.

**END ZONE:**

FOR PURPOSES OF THIS PUBLICATION, DEFINED AS THE END EIGHT FEET (8'-0") OF ONE END OF THE BUILDING. END ZONES DO NOT OCCUR SIMULTANEOUSLY ON BOTH ENDS AT THE SAME TIME.

**GABLE END WALL:**

THE EXTERIOR WALL, WITH AN UPPER VERTICAL TRIANGULAR-SHAPED PORTION, PERPENDICULAR TO THE ROOF RIDGE AND PARALLEL TO ROOF RAFTERS OR TRUSSES.

**GROUT:**

A MIXTURE OF CEMENTITIOUS MATERIAL AND AGGREGATE TO WHICH WATER IS ADDED TO PROVIDE 8" TO 11" SLUMP. COARSE GROUT CONSISTS OF PORTLAND CEMENT, SAND, PEA GRAVEL AND WATER. FINE GROUT CONSISTS OF PORTLAND CEMENT, SAND AND WATER.

**GROUT STOP:**

A PLASTIC SCREEN, METAL LATH STRIP OR CAVITY CAP USED TO PREVENT THE FLOW OF GROUT INTO THE CELLS BELOW.

**INTERIOR ZONE:**

FOR PURPOSES OF THIS PUBLICATION, DEFINED AS ALL BUT THE END EIGHT FEET (8'-0") OF THE BUILDING.

**LENGTH:**

THE DIMENSION OF EXTERIOR WALLS PARALLEL TO THE ROOF RIDGE AND PERPENDICULAR TO THE SPAN OF ROOF RAFTERS OR TRUSSES.

**LENGTH TO WIDTH RATIO:**

LENGTH/WIDTH

**LINTEL:**

A BEAM USED OVER WALL OPENINGS TO CARRY LOADS ACROSS THE OPENING.  
I.E. PRECAST, MASONRY, CAST-IN-PLACE.

**LOADBEARING WALL:**

A WALL THAT SUPPORTS VERTICAL LOAD IN ADDITION TO ITS OWN WEIGHT.

# DEFINITIONS

THE FOLLOWING DEFINITIONS DESCRIBE SOME OF THE TERMINOLOGY USED IN THIS MANUAL:

**MASONRY LINTEL:**

MASONRY LINTEL UNITS ARE USUALLY U-SHAPED WITH SOLID BOTTOM TO CONFINE THE GROUT IN THE LINTEL. WHEN BOND BEAM BLOCK UNITS ARE USED UPSIDE DOWN TO CONSTRUCT LINTELS, THE REINFORCEMENT MUST BE TIED UP TO THE CROSS WEBS TO HOLD THE BARS IN PLACE AND THE BOTTOM MUST BE BLOCKED TO RETAIN THE GROUT.

**SHEARWALL:**

A WALL OR SEGMENT OF WALL DESIGNED TO TRANSFER LATERAL LOADS (WIND LOADS) FROM ROOF TO THE FOUNDATION. THIS VERTICAL STRUCTURAL UNIT ACTS AS A DEEP, THIN, VERTICAL, CANTILEVER BEAM DESIGNED TO RESIST LATERAL FORCES PARALLEL TO THE PLANE OF THE WALL.

**SHEARWALL PIER:**

THE PORTION OF A SHEARWALL SEGMENT ADJACENT TO AND EQUAL IN HEIGHT TO THE OPENING WITH THE SHORTEST HEIGHT ON EITHER SIDE OF THE SHEARWALL SEGMENT.

**SHEARWALL PIER HEIGHT:**

THE HEIGHT OF THE SHORTEST OPENING HEIGHT ON EITHER SIDE OF A SHEARWALL SEGMENT.

**SHEATHING:**

THE STRUCTURAL COVERING USED DIRECTLY OVER STUDS, TRUSSES OR RAFTERS OF A STRUCTURE TO RESIST LATERAL LOADS.

**WIDTH:**

THE DIMENSION OF EXTERIOR WALLS PERPENDICULAR TO THE ROOF RIDGE AND PARALLEL TO THE SPAN OF ROOF RAFTERS OR TRUSSES.

**This guide is provided in three separate design sections.** The first design section provides the design criteria for buildings designed for 90 mile per hour wind speeds. The second design section provides the design criteria for buildings designed for 100 mile per hour wind speeds. The third design section provides the design criteria for buildings designed for 110 mile per hour wind speeds. **For simplicity, the drawings and elevations on pages 1.9 and 1.10 refer to the sheet numbers for various design aspects of a typical residence. These sheet number references apply to the 90, 100 and 110 mile per hour wind speed tables and figures, should the design wind speed be 90, 100 or 110 mile per hour.**

This document is limited to use in the design of single-story, concrete masonry buildings. In general:

- Concrete slab-on-grade or crawl space.
- Top of floor is not more than 3 feet above grade.
- Maximum truss span is 40'-0" clear between supports.
- Maximum width or length is 80 feet; maximum height is 25 feet.
- Ceiling heights are not more than 10 feet.
- Exterior walls are constructed with 8" concrete masonry units.
- Roof pitches are no less than 2:12 (10 degrees) and no greater than 7:12 (30 degrees).
- Roof sheathing is at least 7/16 inches thick.
- Building length/width ratio no greater than 2:1 and no less than 1:2.
- Building legs (for "T" or "L" shaped buildings) have a maximum length/width ratio of 2:1, but have no minimum length/width ratio.
- The roof overhang is limited to a maximum of 2 feet.
- Interior bearing walls are constructed with 6" or 8" concrete masonry units.

## DESIGN LOAD ASSUMPTIONS

### Design Wind Loads:

Main Wind Force Resisting Systems (MWFRS): Design of the following structural systems and connections were based on the coefficients given in the Standard Building Code.

1. shearwalls,
2. roof diaphragms,
3. bond beams,
4. gable and endwalls,
5. rafter and truss connectors to bond beams and,
6. all other connector links in the wind resistance chain to uplift, overturning and sliding.
7. exterior masonry walls in conjunction with uplift loads.

Components and Cladding (C&C): The elements of the building designed under the provisions for C&C and maximum tributary area assumed include:

1. sheathing fasteners, maximum tributary area of 10 sq. ft.,
2. wood structural panels spans are based upon a minimum of two continuous spans (over three framing members).
3. exterior masonry walls, without any uplift forces, per Table 1606.2E, 1994 SBC, interior zone.

### Live Loads:

Construction and other live loads acting on the building must not exceed a roof load of 20 psf with the normal reduction permitted for large tributary areas, in accordance with the Standard Building Code.

## Dead Loads:

In developing the provisions of the Guide, the following assumptions were made about the magnitude, distribution, and influence of dead loads:

1. The total weight of roofing materials, ceiling, insulation, framing members, and other materials supported directly by the roof trusses or rafters does not exceed 25 psf on the horizontal projection.
2. For determination of resistance to uplift, sliding, and overturning of the gross building, the roof dead load was taken as 10 psf.
3. Overturning resistance was based on the total building dead load.

## MASONRY AND REINFORCING STEEL

Concrete masonry units shall be hollow unit masonry in accordance with ASTM C 90 and shall have a minimum net area compressive strength of 1900 psi when using Type M or S mortar (ASTM C 270). In accordance with ACI 530, the 1900 psi block in combination with Type M or S mortar provide a design compressive strength ( $f'_m$ ) of 1500 psi. The reinforcement shall be a minimum Grade 40 and identified in accordance with ASTM A 615.

Reinforcement Splices: Lap splice lengths shall be a minimum of 25 inches for #5 bars, 30 inches for #6 bars and 35 inches for #7 bars.

Reinforcement Substitutions: Where two #5 bars are required within the same grouted masonry cell or bond beam, one #7 bar may be substituted.

Bending Reinforcement: All reinforcement shall be bent cold, in the shop or in the field, provided the bend diameter, measured on the inside of the bar, is not less than six-bar diameters. Reinforcement partially embedded in concrete shall not be field bent. **EXCEPTION:** If bending is necessary to align dowel bars with a vertical cell, bars partially embedded in concrete shall be permitted to be bent at a slope of not more than 1 inch of horizontal displacement to 6 inches of vertical bar length.

Grout: The grout shall have a maximum course aggregate size of 3/8 inch placed at an 8 to 11 inch slump and have a minimum specified compressive strength of 2000 psi at 28 days when tested in accordance with ASTM C 1019, or shall be in accordance with ASTM C 476.

Masonry Cleanout: Cleanout openings (12 sq. in.) shall be provided for cells containing spliced reinforcement when the grout pour exceeds 5 feet in height.

Concrete Walls: Cast in place concrete walls can be used as an alternate to masonry walls. Refer to SSTD 10 for equivalent wall thicknesses and additional design requirements.

## ENGINEERED WOOD ROOF TRUSS FRAMING SYSTEMS

Trusses shall be designed by a registered engineer or architect in accordance with ANSI/TPI National Design Specifications for Metal Plate Connected Wood Truss Construction. The top chords of trusses shall be Group II species lumber, with a specific gravity  $G=0.46$  or greater.

Truss Spacing: Metal plate connected wood trusses shall be spaced no more than 24 inches on center and designed for live loads and wind loads for an enclosed building based on the Standard Building Code.

# HOW TO USE THIS GUIDE

Connections: Uplift connectors shall be provided at truss bearing to resist uplift loads and loads parallel and perpendicular to the masonry wall. The uplift requirements may be interpolated for intermediate building widths.

Separation: Provide approved separation between untreated wood and concrete or masonry.

## FASTENERS AND CONNECTORS

A continuous load path between foundations, floors, walls, and roof framing shall be provided.

Approved connectors, anchors, and other fastening devices not included in the Standard Building Code shall be installed in accordance with the manufacturer's recommendations. Where fasteners are not otherwise specified in this Guide, fasteners shall be provided in accordance with the Standard Building Code. Nails, screws, or bolts shall be able to resist the forces specified in this Guide. (See NER 272 for information on power driven fasteners)

Metal plates, connectors, screws, bolts and nails exposed directly to the weather or subject to salt corrosion in coastal areas, as determined by the Building Official, shall be stainless steel, hot dipped galvanized after the fastener or connector is fabricated, to form a zinc coating not less than 1 oz. per sq. ft., or hot dipped galvanized coated with a minimum of 1.8 oz. per sq. ft. of steel meeting the requirements of ASTM 90 Triple Spot Test.

Unless otherwise stated, sizes given for nails are common wire nails. For example, 8d = 2 ½ in. long x 0.131 in. diameter. See the National Design Specifications for Wood Construction.



## TYPICAL ROOF PLANS

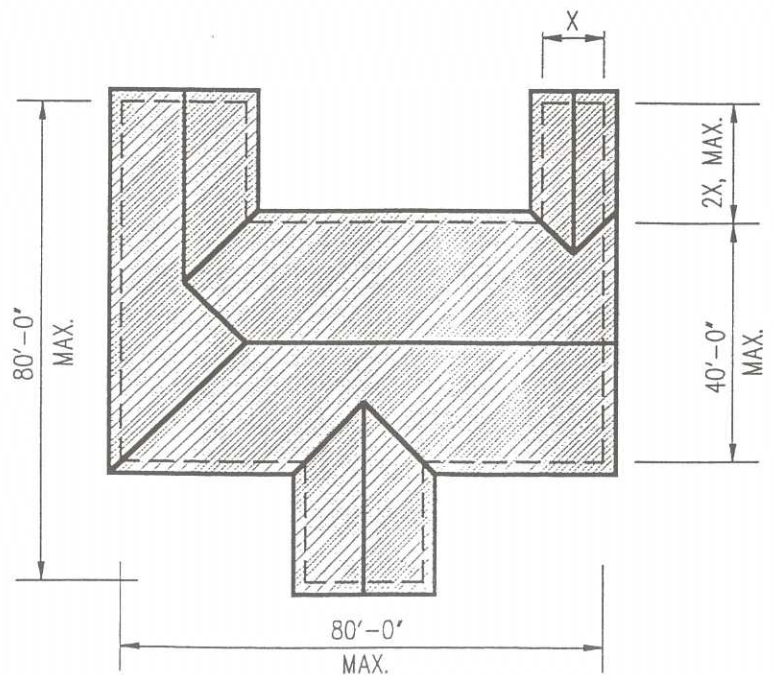
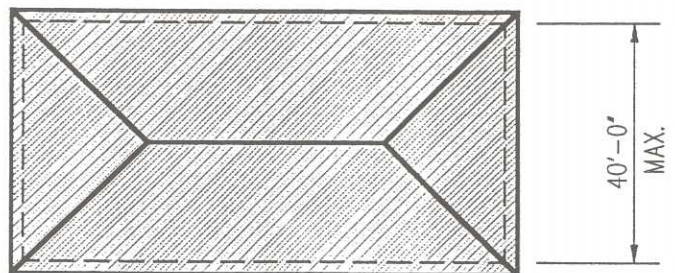
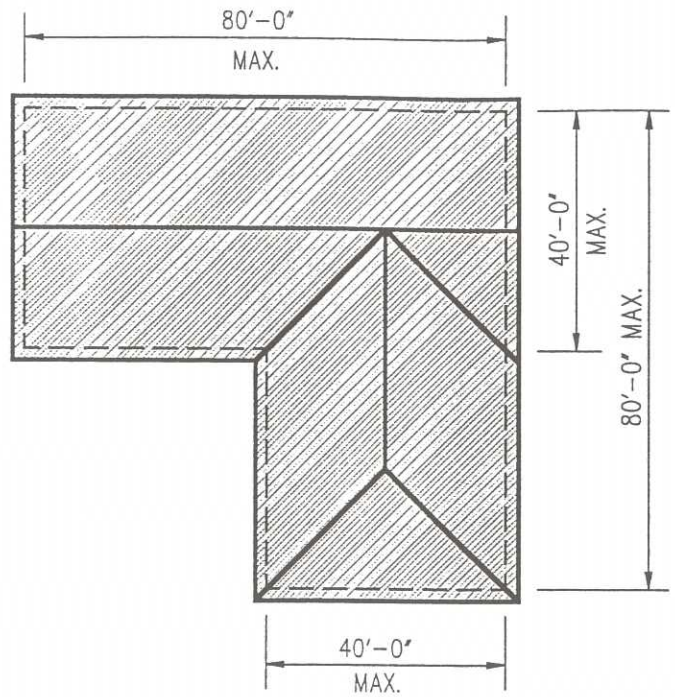
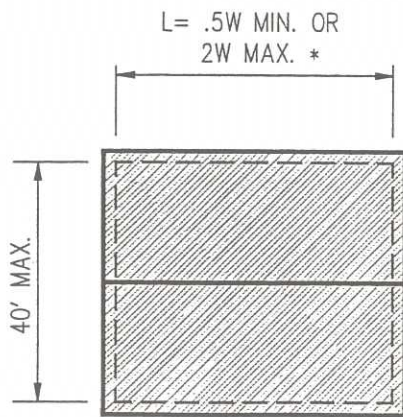

### NOTE

THESE ROOF PLANS SHOW TYPICAL CONFIGURATIONS & SHAPES TO CONVEY THE RANGE OF THE SYSTEM.

GABLES & HIPS ARE INTERCHANGEABLE FOR PLANS SHOWN.

\* THE MAIN BUILDING MAXIMUM DIMENSIONS ARE 40'x80'.

# KEY EXAMPLE PLAN

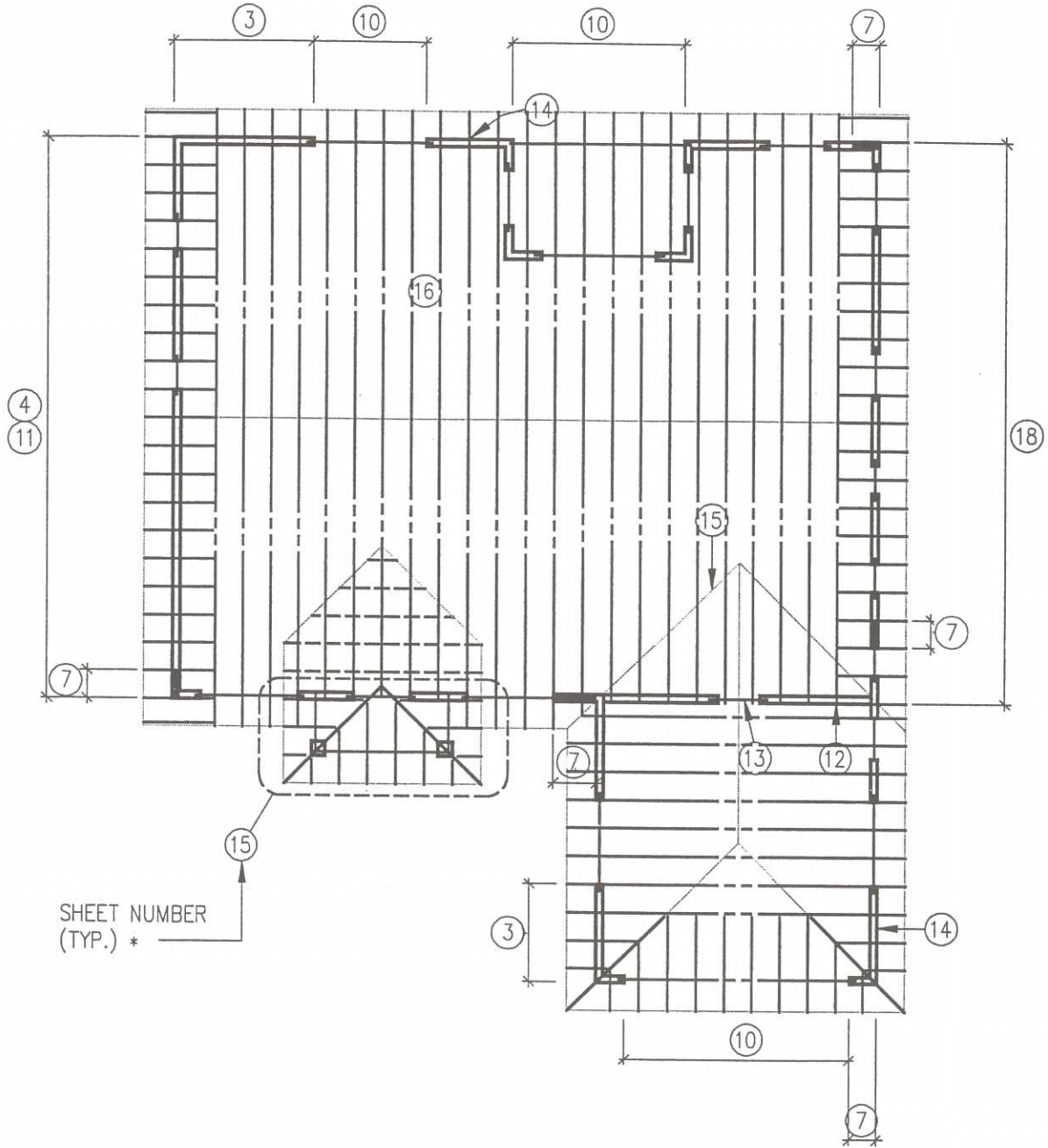

PLAN

\* REFER TO THE CORRESPONDING WIND SPEED SECTION FOR THE SHEET NUMBER REFERENCED ABOVE.  
 (EXAMPLE: FOR SHEET 10, GO TO 90.10, 100.10 OR 110.10)

# KEY EXAMPLE ELEVATIONS

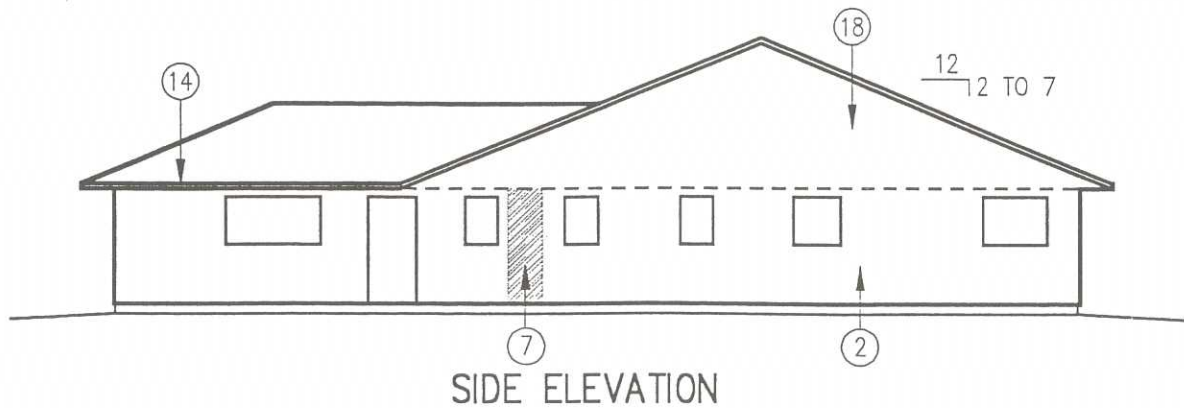
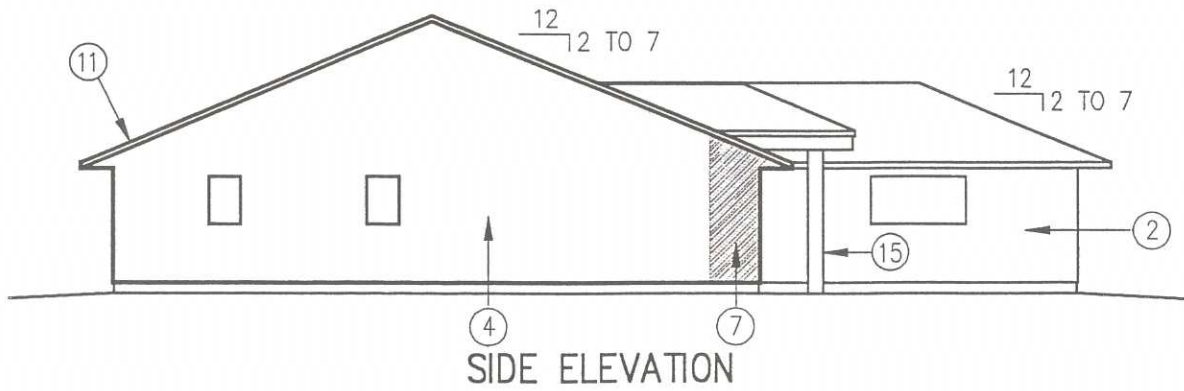
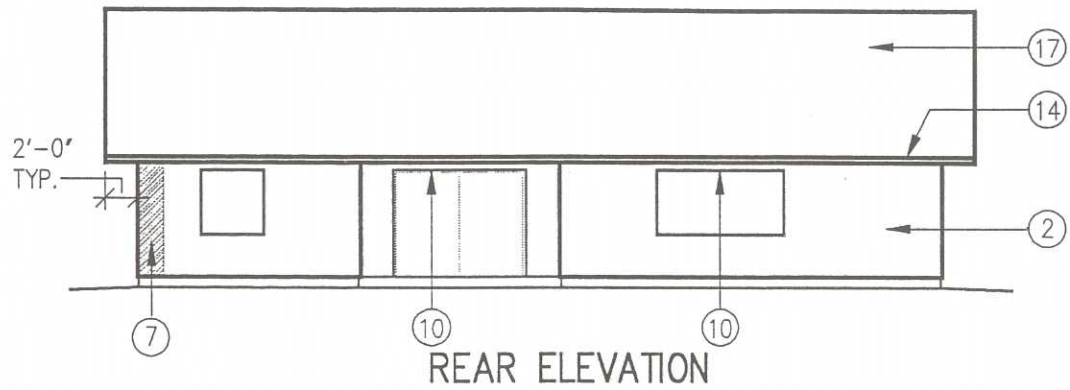
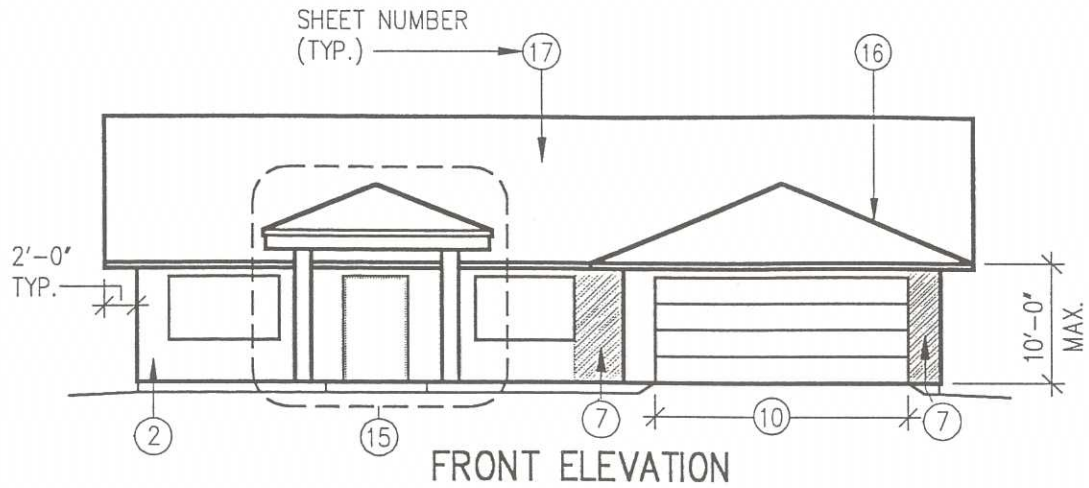

# TYPICAL WALL SECTION

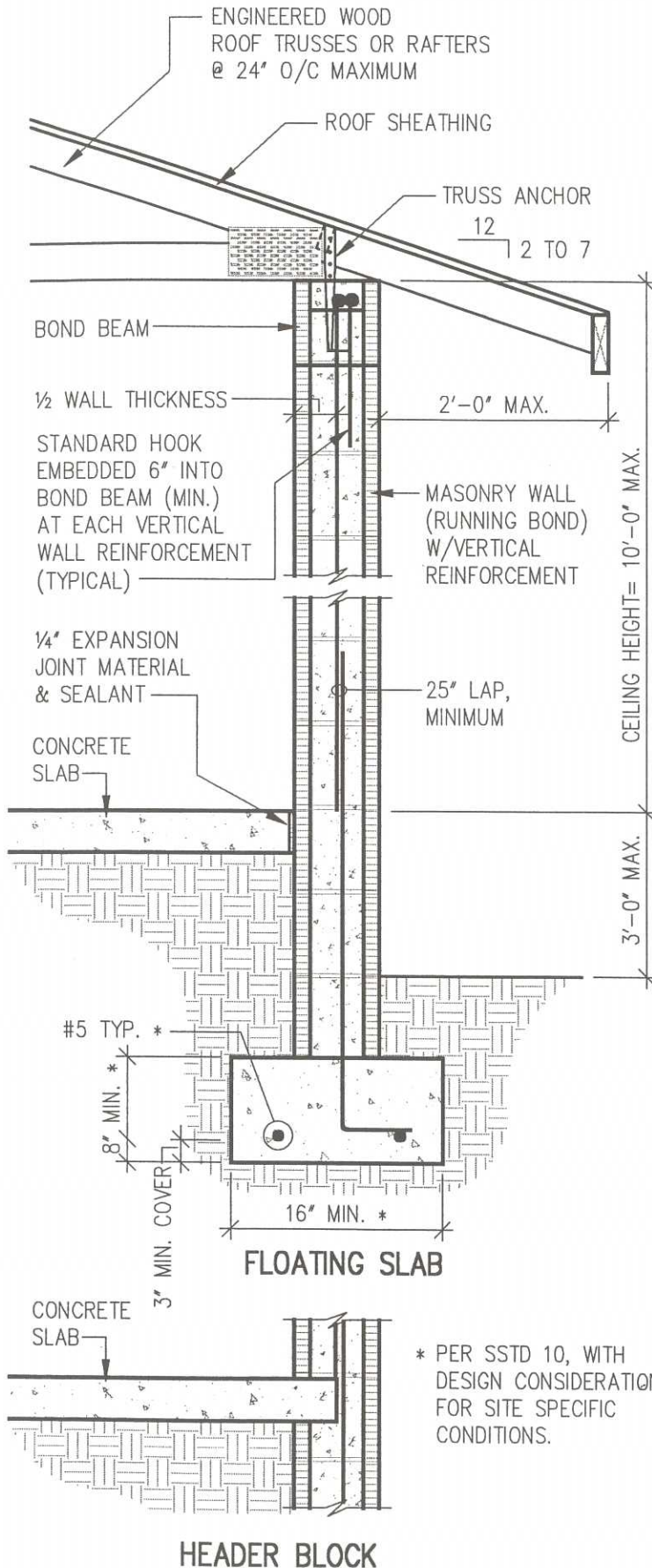

\* PER SSTD 10, WITH DESIGN CONSIDERATIONS FOR SITE SPECIFIC CONDITIONS.

## DESIGN CODES

1994 STANDARD BUILDING CODE  
WITH 1996 REVISIONS AND 1997 SBC  
1991 NATIONAL DESIGN SPECIFICATION  
ACI 530-95  
SSTD 10-97

## DESIGN LOADS AT ROOF

LIVE LOAD= 20 PSF  
DEAD LOAD= 10 TO 25 PSF

## ROOF SHAPES

GABLE OR HIP

## DESIGN WIND VELOCITY

90, 100 OR 110 MPH

## TRUSS SPAN

MAXIMUM 40'-0" CLEAR  
BETWEEN SUPPORTS

## BUILDING DIMENSIONS

MAXIMUM DIMENSION= 80'-0"

## MATERIAL PROPERTIES

(MINIMUM)  
CONCRETE  $f'_c$ = 2500 psi  
MASONRY  $f'_m$ = 1500 psi  
REINFORCEMENT GRADE 40  
MORTAR TYPE M OR S  
GROUT STRENGTH= 2000 PSI

## TYPES OF BOND BEAMS

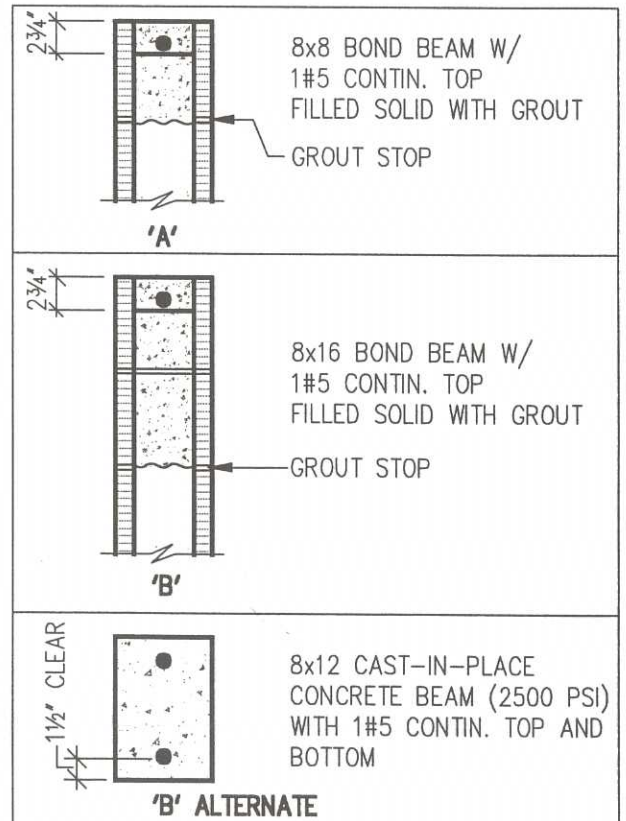

# TABLE OF CONTENTS (90 mph)

## GUIDE TO CONCRETE MASONRY RESIDENTIAL CONSTRUCTION IN HIGH WIND AREAS 90 MPH DESIGN WIND SPEED VELOCITY

90.1	Table of Contents - 90 mph Design Wind Velocity
90.2	Vertical Reinforcement Details
90.3	Vertical Reinforcement Spacing
90.4	Gable Endwall Vertical Reinforcement
90.5	Shearwall Design Notes
90.6	Shearwall Proportioning Example
90.7	Shearwall Design Table
90.8	Lintel Types
90.9	Lintel Types - Continued
90.10	Lintel Schedule
90.11	Gable Endwall Details
90.12	Interior Bearing Wall Detail
90.13	Interior Bearing Wall Openings
90.14	Roof Truss Anchor
90.15	Entry Condition Details
90.16	Valley / Hip Detail
90.17	Roof Sheathing Attachment
90.18	Alternate Gable End Detail
90.19	Alternate Gable End Detail - Cont.
90.20	Alternate Gable End Detail - Cont.

# VERTICAL REINFORCEMENT DETAILS

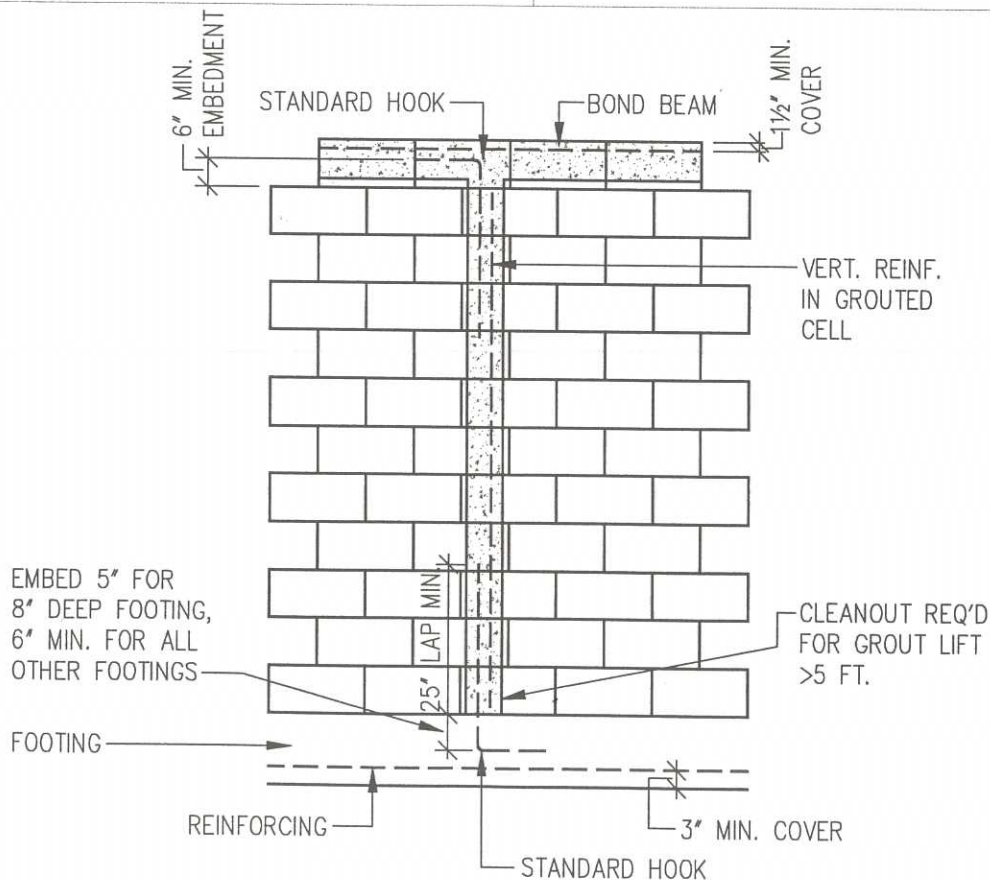
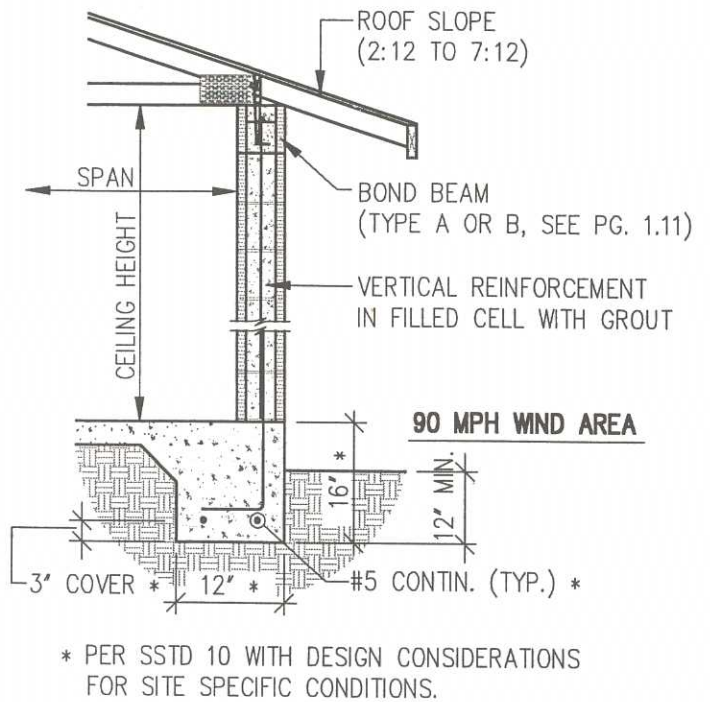
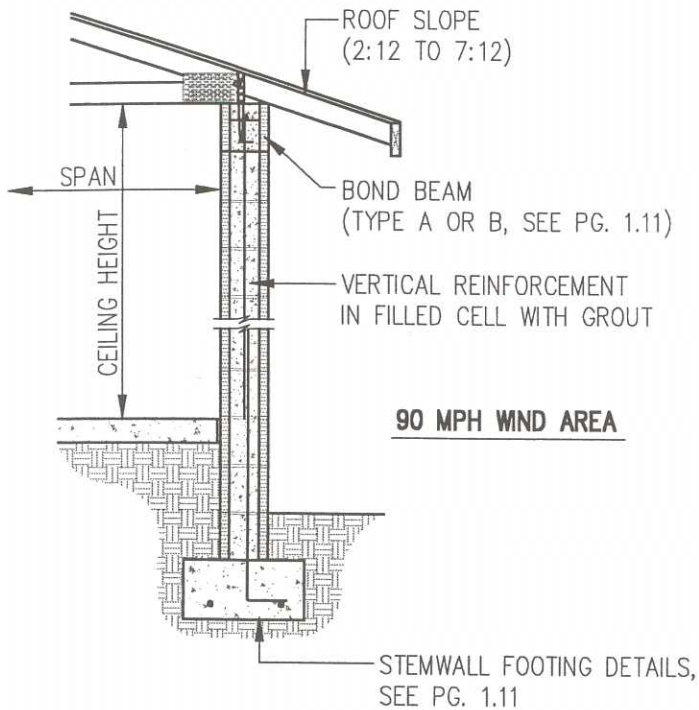

# VERTICAL REINFORCEMENT SPACING

<b>MAXIMUM SPACING OF #5 BAR IN FILLED CELLS</b>				
CEILING HEIGHT	BOND BEAM ⑤	SPAN 0'-20'	SPAN >20' TO 30'	SPAN >30' TO 40'
<b>8'-0" OR LESS</b>	A	15'-4"	14'-0"	12'-8"
	B	15'-4"	15'-4"	15'-4"
<b>8'-8"</b>	A	12'-8"	12'-8"	12'-8"
	B	12'-8"	12'-8"	12'-8"
<b>9'-4"</b>	A	11'-4"	11'-4"	11'-4"
	B	11'-4"	11'-4"	11'-4"
<b>10'-0"</b>	A	9'-4"	9'-4"	9'-4"
	B	9'-4"	9'-4"	9'-4"

NOTE:

1. PROVIDE ONE #5 BAR IN GROUTED CELL AT ALL WALL CORNERS AND INTERSECTIONS.
2. PROVIDE 1 #5 BAR IN GROUTED CELL AT EACH SIDE OF OPENINGS WIDER THAN 6'-0" AND AT EACH END OF SHEARWALL SEGMENTS. PROVIDE 2 #5 BARS ON EACH SIDE OF OPENINGS WIDER THAN 12'-0".
3. PROVIDE ONE #5 BAR IN GROUTED CELL AT ALL LOCATIONS WHERE GIRDERS OR GIRDER TRUSSES BEAR ON THE MASONRY WALL.
4. REDISTRIBUTE VERTICAL REINFORCEMENT ABOVE OPENINGS TO EACH SIDE OF OPENING. PROVIDE ½ OF THE REINFORCEMENT INTERRUPTED BY THE OPENING OR THE AMOUNT REQUIRED IN NOTE 2, WHICHEVER IS GREATER, ON EACH SIDE OF THE OPENING.
5. SEE PG. 1.11 FOR DESCRIPTION OF BOND BEAM TYPES 'A' AND 'B'.

# CONTINUOUS MASONRY GABLE END WALL VERTICAL REINFORCEMENT

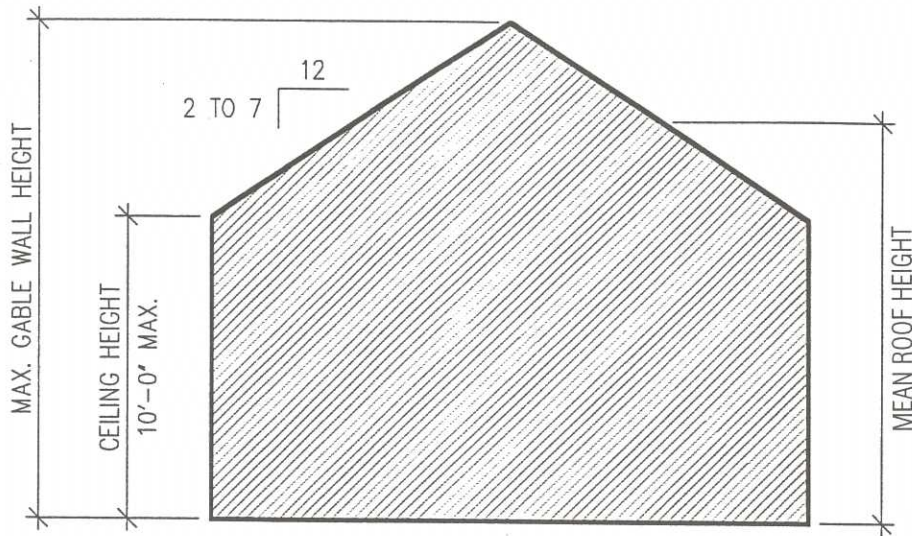

$$\text{MEAN ROOF HEIGHT} = \frac{\text{CEILING HEIGHT} + \text{MAX. GABLE HEIGHT}}{2}$$

TO DETERMINE THE VERTICAL SPACING REQUIRED FOR CONTINUOUS MASONRY GABLE WALLS, USE ONE OF THE FOLLOWING METHODS:

- METHOD 1.) DETERMINE THE MEAN ROOF HEIGHT OF THE GABLE END WALL AND USE THAT WALL HEIGHT IN THE TABLE BELOW TO OBTAIN THE VERTICAL REINFORCEMENT SPACING FOR THE ENTIRE WALL.
- METHOD 2.) DIVIDE THE GABLE WALL INTO SEGMENTS AND VARY THE VERTICAL SPACING BASED ON THE AVERAGE WALL HEIGHT IN EACH SEGMENT.

HEIGHT (EITHER BY METHOD 1 OR BY METHOD 2)	8' TO 10'	> 10' TO 13'	> 13' TO 16'	> 16' TO 19'	> 19' TO 22'
MAXIMUM SPACING OF 1#5 IN FILLED CELLS	9'-4"	5'-4"	3'-4"	2'-8"	1'-4"



## NOTES ON SHEARWALL LENGTH DESIGN

- 1.) MINIMUM SHEARWALL SEGMENT LENGTH SHALL BE 2'-0".  
FILLED CELL WITH 1#5 BAR REQUIRED AT EACH END OF SHEARWALL SEGMENT.
- 2.) PORTIONS OF WALLS WITH OPENINGS SHALL NOT BE CONSIDERED PART OF THE SHEARWALL LENGTH.
- 3.) THE CUMULATIVE SHEARWALL LENGTH FOR EACH SIDE OF THE BUILDING MUST BE EQUAL TO OR GREATER THAN THE TABULATED SHEARWALL LENGTH REQUIRED.

\* DOES NOT HAVE TO BE CONTINUOUS, AS LONG AS TOTAL LENGTH OF SEPARATE SEGMENTS MEETS THE SHEARWALL LENGTH REQUIREMENTS.

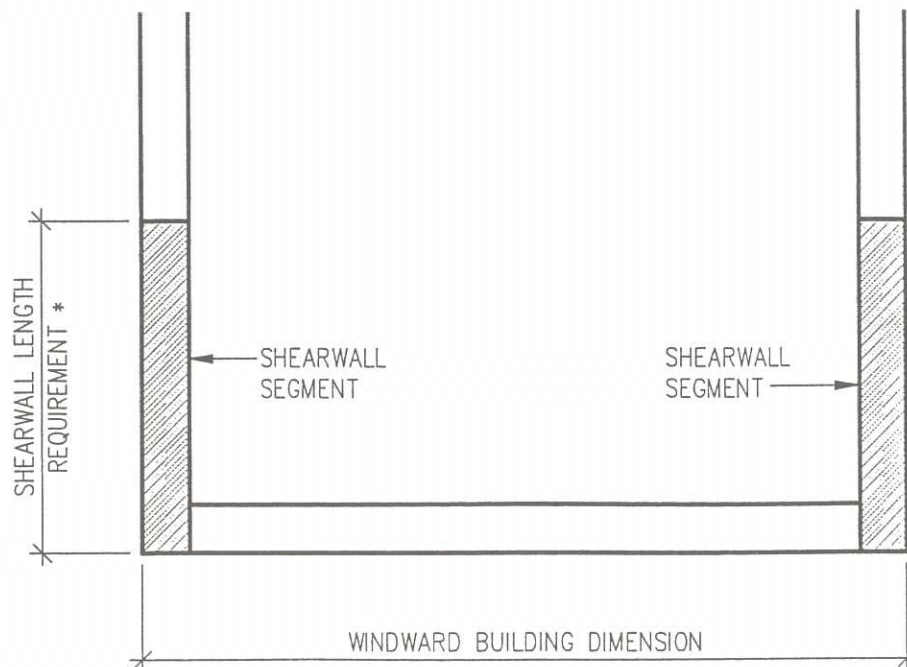

# SHEARWALL PROPORTIONING EXAMPLE

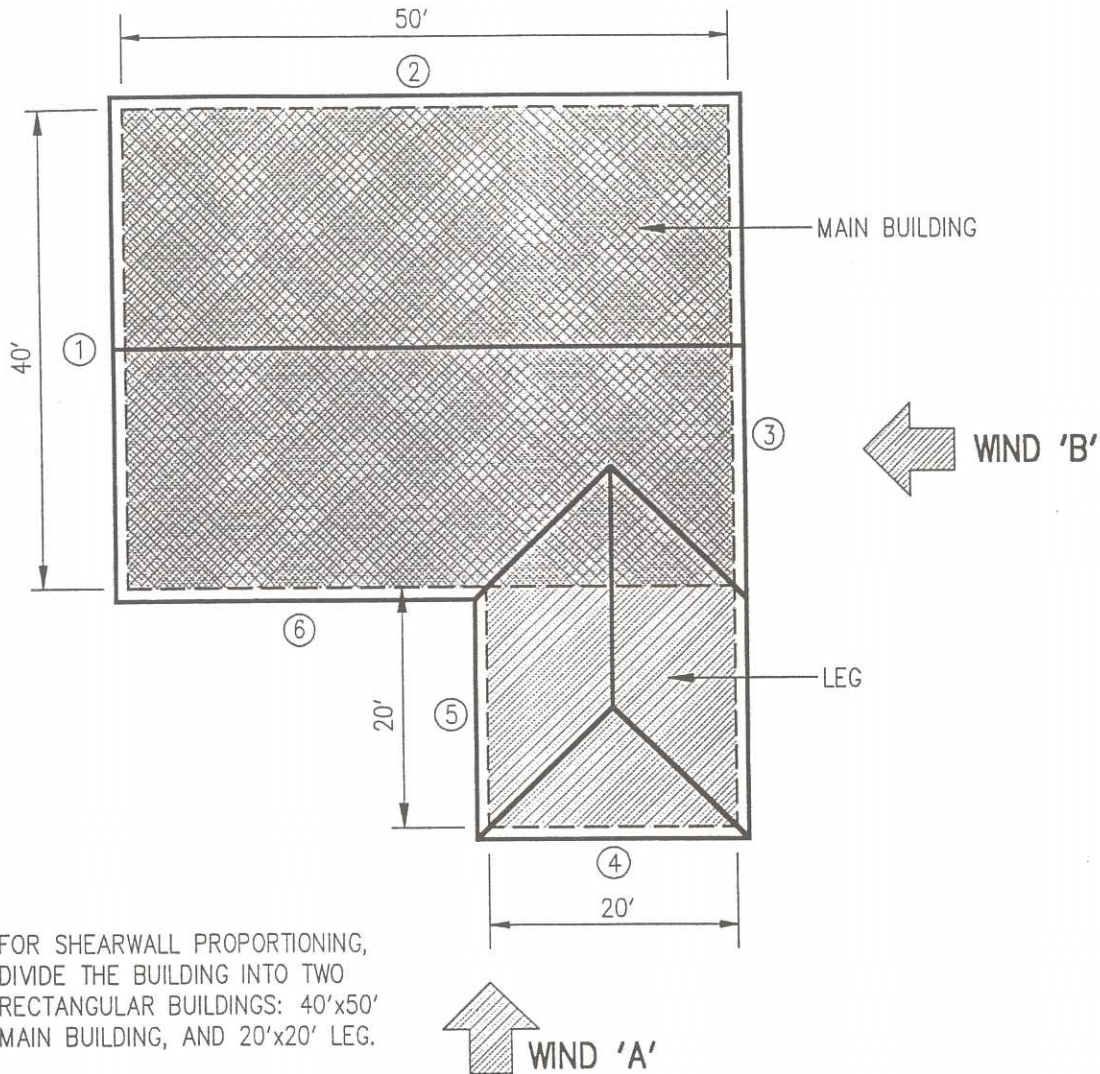

## WIND 'A'

TO DETERMINE THE AMOUNT OF SHEARWALL REQUIRED IN ①, ③ AND ⑤, THE "WINDWARD MAIN BUILDING DIMENSION" IS 50'. PER THE TABLE ON 90.4, THE REQUIRED SHEARWALL LENGTH IS 1'-4". HOWEVER, THE MINIMUM SHEARWALL SEGMENT LENGTH IS 2'-0". THEREFORE PROVIDE A 2'-0" SEGMENT IN ① AND A 2'-0" SEGMENT IN ③. ⑤ DOES NOT HAVE A SHEARWALL REQUIREMENT BECAUSE THE WINDWARD BUILDING AREA OF THE MAIN BUILDING WAS NOT INCREASED BY THE LEG.

## WIND 'B'

TO DETERMINE THE AMOUNT OF SHEARWALL REQUIRED IN ②, ④ AND ⑥, THE LENGTH REQUIRED IN ② AND THE MAIN BUILDING PORTION OF ⑥ IS BASED UPON 40' FOR A GABLE END. THE LENGTH REQUIRED FOR ④ AND THE LEG PORTION OF ⑥ IS BASED UPON 20'. THE SHEARWALL LENGTH IN ⑥ SHALL BE EQUAL TO THE SUM OF ② AND ④. FOR THIS EXAMPLE, ② REQUIRES 1'-10" (2'-0" MIN.), ④ REQUIRES 0'-4" (2'-0" MIN.) AND ⑥ REQUIRES 2'-2" (1'-10" + 0'-4").

# SHEARWALL DESIGN TABLE







## 90 MPH WIND AREA





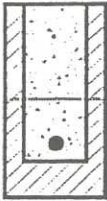
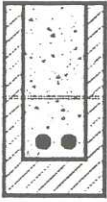
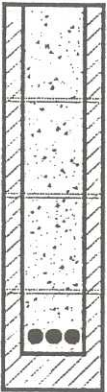

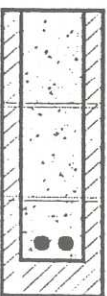
REQUIRED SHEARWALL LENGTH (2:12 TO 7:12 ROOF SLOPE)

WINDWARD BUILDING DIMENSION	SHEARWALL LENGTH REQUIRED (EACH SIDE) OF BUILDING (EXCEPT GABLE END WINDS)	SHEARWALL LENGTH REQUIRED (EACH SIDE) OF BUILDING PERPENDICULAR TO GABLE END
10' TO 20'	0'-4" *	0'-5" *
>20' TO 30'	0'-8" *	1'-1" *
>30' TO 40'	1'-0" *	1'-10" *
>40' TO 50'	1'-4" *	
>50' TO 60'	1'-9" *	
>60' TO 70'	2'-1"	
>70' TO 80'	2'-5"	
* 2'-0" MINIMUM SHEARWALL SEGMENT LENGTH		

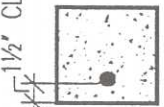
NOTE: MAXIMUM SHEARWALL PIER HEIGHT= 6'-0" FOR 2'-0" LENGTH. A MAXIMUM SHEARWALL PIER HEIGHT OF 8'-8" IS ALLOWED FOR SHEARWALL LENGTHS OF 2'-8" OR GREATER.

# LINTEL TYPES

 <p>8x8 MASONRY LINTEL W/1#5 BOTTOM FILLED SOLID WITH GROUT</p> <p>'A2'</p>	 <p>8x32 MASONRY LINTEL W/2#5 BOTTOM FILLED SOLID WITH GROUT</p> <p>'D'</p>
 <p>8x16 MASONRY LINTEL W/1#5 BOTTOM FILLED SOLID WITH GROUT</p> <p>'B2'</p>	
 <p>8x16 MASONRY LINTEL W/2#5 BOTTOM FILLED SOLID WITH GROUT</p> <p>'B3'</p>	 <p>8x32 MASONRY LINTEL W/3#5 BOTTOM FILLED SOLID WITH GROUT</p> <p>'D2'</p>
 <p>8x24 MASONRY LINTEL W/1#5 BOTTOM FILLED SOLID WITH GROUT</p> <p>'C'</p>	
 <p>8x24 MASONRY LINTEL W/2#5 BOTTOM FILLED SOLID WITH GROUT</p> <p>'C2'</p>	 <p>8x40 MASONRY LINTEL W/3#5 BOTTOM FILLED SOLID WITH GROUT</p> <p>'E'</p>

<p>1 1/2" CLEAR (TYP.)</p>  <p>'F'</p> <p>8x8 CAST IN PLACE CONCRETE BEAM (2500 PSI) WITH 1#5 BOTTOM</p>	<p>1 1/2" CLEAR (TYPICAL)</p>  <p>'K'</p> <p>2#5 #3 STIRRUPS @7" O/C 2#5</p> <p>8x16 CAST IN PLACE CONCRETE BEAM (2500 PSI)</p>
 <p>'G'</p> <p>8x16 CAST IN PLACE CONCRETE BEAM (2500 PSI) WITH 2#5 BOTTOM</p>	 <p>'L'</p> <p>2#5 #3 STIRRUPS @11" O/C 2#6</p> <p>8x24 CAST IN PLACE CONCRETE BEAM (2500 PSI)</p>
 <p>'H'</p> <p>8x24 CAST IN PLACE CONCRETE BEAM (2500 PSI) WITH 2#6 BOTTOM</p>	 <p>'M'</p> <p>2#5 #3 STIRRUPS @15" O/C 4#6</p> <p>8x32 CAST IN PLACE CONCRETE BEAM (2500 PSI)</p>
 <p>'J'</p> <p>8x32 CAST IN PLACE CONCRETE BEAM (2500 PSI) WITH 2#7 BOTTOM</p>	

# LINTEL SCHEDULE

LINTEL SCHEDULE				
MAX. CLEAR OPENING WIDTH	ROOF TRUSS SPAN	PRECAST LINTEL ALLOWABLE LOAD (PLF) ③	MASONRY LINTEL	CAST IN PLACE BEAMS
UP TO 3'-0"	0' TO 20'	650	A2	F
	>20' TO 30'	875	A2	G
	>30' TO 40'	1,100	A2	G
>3'-0" TO 6'-0"	0' TO 20'	650	B2	G
	>20' TO 30'	875	B2	G
	>30' TO 40'	1,100	B2	H OR K
>6'-0" TO 9'-0"	0' TO 20'	650	B3	H OR K
	>20' TO 30'	875	C	H OR K
	>30' TO 40'	1,100	C2	J OR K
>9'-0" TO 12'-0"	0' TO 20'	650	C2	H OR K
	>20' TO 30'	875	C2	J OR L
	>30' TO 40'	1,100	D	L
>12'-0" TO 15'-0"	0' TO 20'	650	D	J OR L
	>20' TO 30'	875	D	L
	>30' TO 40'	1,100	D2	M
>15'-0" TO 18'-0"	0' TO 20'	650	D	L
	>20' TO 30'	875	E	M
	>30' TO 40'	1,100	E	M

NOTE:

1. MUST MAINTAIN CONTINUITY OF BOND BEAM AT TOP OF WALL.
2. IF MASONRY OPENING EXCEEDS SCHEDULED VERTICAL REINFORCEMENT SPACING, THEN LINTEL, BOND BEAM AND WALL ABOVE OPENING SHALL BE FILLED SOLID OVER OPENING WIDTH.
3. RATED CAPACITY OF PRECAST LINTEL BY ITSELF OR THROUGH COMPOSITE ACTION WITH OTHER ELEMENTS.

# GABLE ENDWALL DETAILS

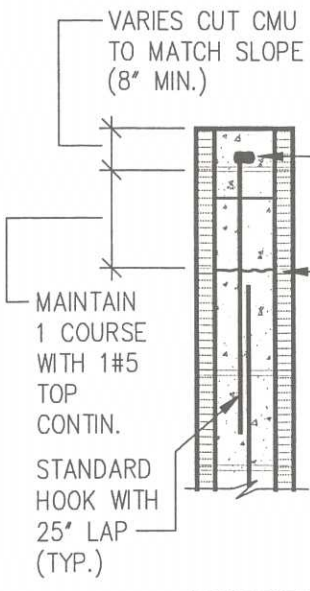
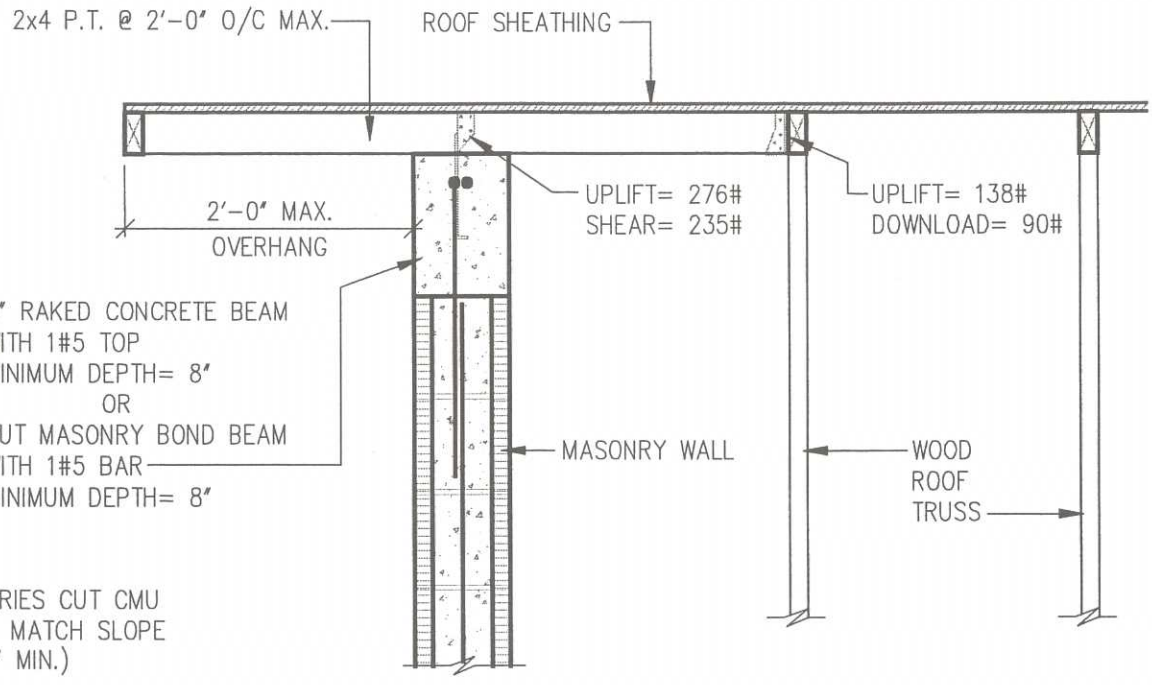
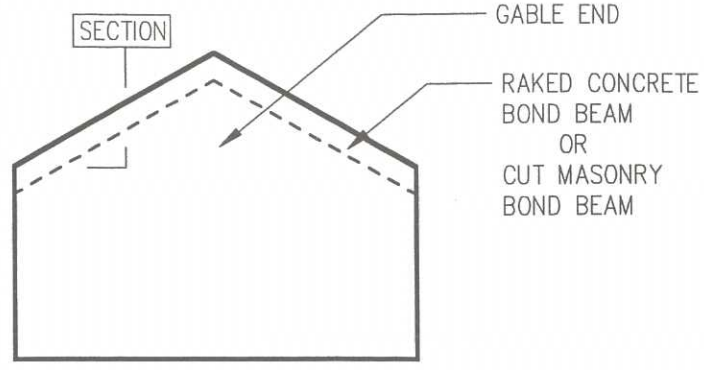

ALTERNATE CUT MASONRY BOND BEAM

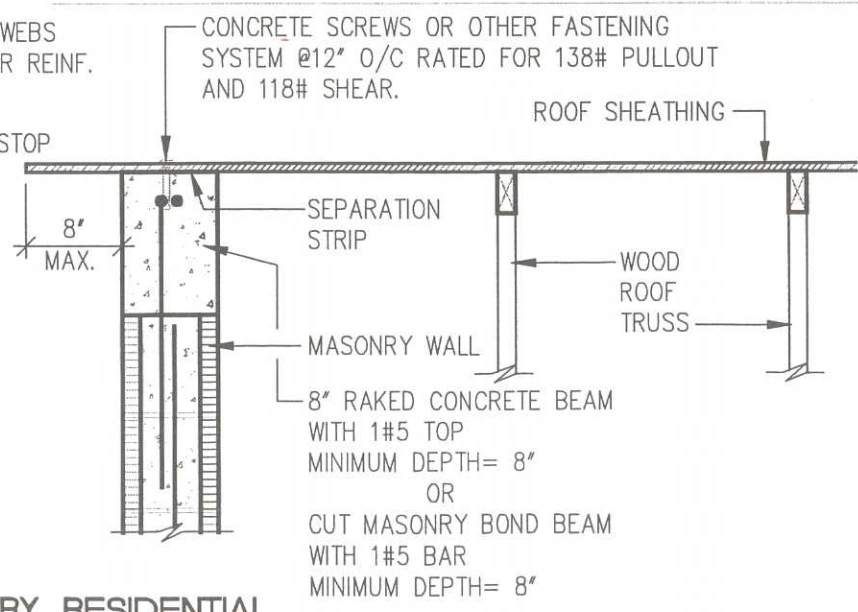

# INTERIOR BEARING WALL DETAIL

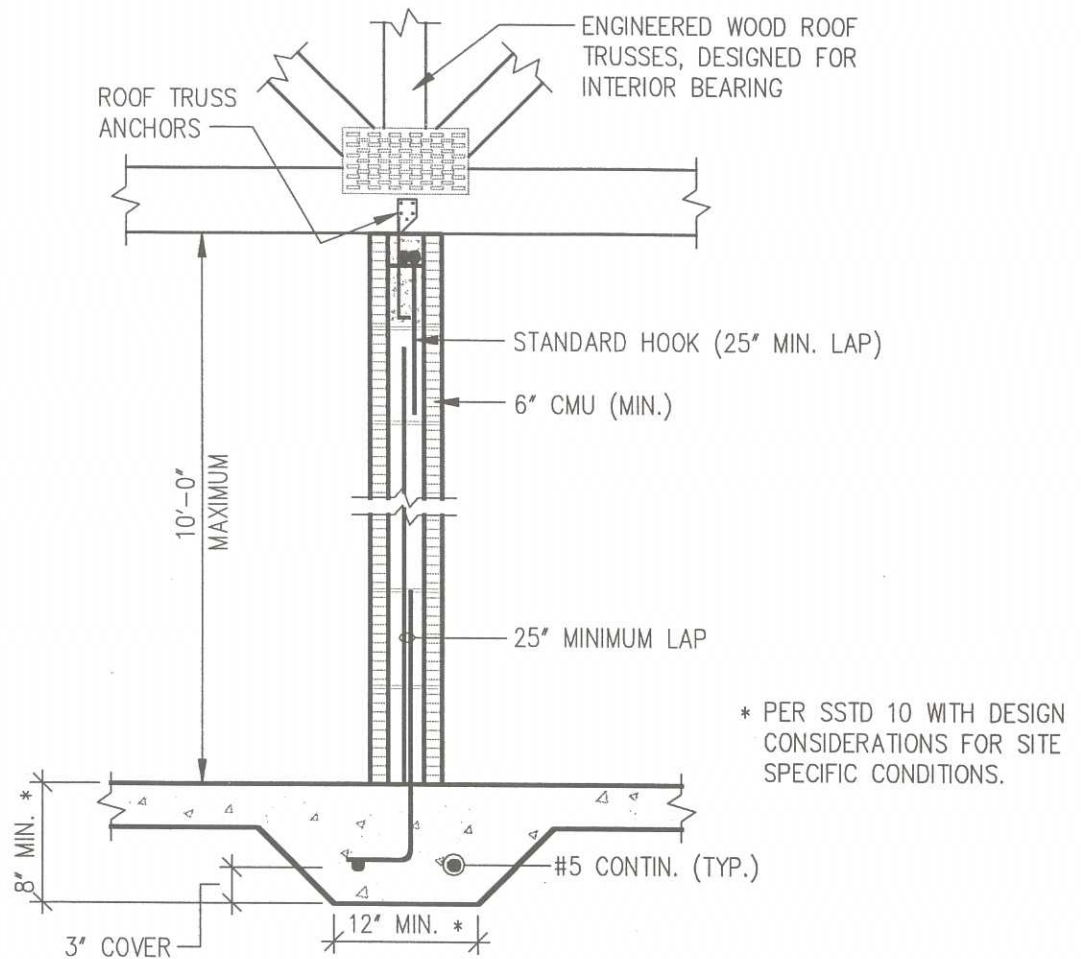

SPAN	ROOF TRUSS ANCHOR NET UPLIFT (LBS) (TRUSSES @ 24")		MAX. SPACING OF #5 BAR IN FILLED CELL	
	INTERIOR ZONE	END ZONE (TRUSSES 8' OR CLOSER TO OUTSIDE OF ENDWALL)	BOND BEAM 'A' (6x8)	BOND BEAM 'B' (6x16)
10'	57	114	16'-0"	24'-0"
20'	114	228	12'-0"	24'-0"
30'	171	342	10'-8"	20'-0"
40'	228	456	9'-4"	17'-4"
50'	285	570	8'-0"	16'-0"
60'	342	684	7'-4"	14'-8"
70'	399	798	6'-8"	14'-0"
80'	456	912	6'-0"	13'-4"

**NOTE:**

1. PROVIDE ONE #5 BAR IN GROUTED CELL AT CORNERS AND INTERSECTIONS.
2. PROVIDE 1 #5 BAR IN GROUTED CELL AT EACH SIDE OF OPENINGS WIDER THAN A 6'-0" AND 2 #5 BARS ON EACH SIDE OF OPENINGS WIDER THAN 12'-0".
3. PROVIDE ONE #5 BAR IN GROUTED CELL AT ALL LOCATIONS WHERE GIRDERS OR GIRDER TRUSSES BEAR ON THE MASONRY WALL.
4. INTERIOR BEARING WALLS MAY BE CONSTRUCTED OF ALTERNATE MATERIALS IN ACCORDANCE WITH ACCEPTED STANDARDS.



# INTERIOR BEARING WALL OPENINGS

LINTEL SCHEDULE FOR 6" CMU INTERIOR WALLS				
TRUSS SPAN ⑤	OPENING WIDTH	PRECAST LINTEL ALLOWABLE LOAD (PLF)	MASONRY LINTEL	CAST IN PLACE BEAMS ④
0' TO 20'	0' TO 6' > 6' TO 9' > 6' TO 12'	617	B2 B3 C2	G H OR K J OR L
>20' TO 30'	0' TO 6' > 6' TO 9' > 6' TO 12'	842	B2 C D	H OR K J OR K L
>30' TO 40'	0' TO 6' > 6' TO 9' > 6' TO 12'	1067	C D E	H OR K J OR K L
>40' TO 50'	0' TO 6' > 6' TO 9' > 6' TO 12'	1292	C D E	J OR K K L
>50' TO 60'	0' TO 6' > 6' TO 9' > 6' TO 12'	1517	C E —	J OR K L L
>60' TO 70'	0' TO 6' > 6' TO 9' > 6' TO 12'	1742	D E —	K L M
>70' TO 80'	0' TO 6' > 6' TO 9' > 6' TO 12'	1967	D — —	K L M

**NOTE:**

- 1.) MUST MAINTAIN CONTINUITY OF BOND BEAM.
- 2.) LINTEL TYPES REFERENCED ARE SIMILAR TO 8" LINTELS (90.8) EXCEPT THE BEAM WIDTH IS 6".
- 3.) IF MASONRY OPENING EXCEEDS SCHEDULED VERTICAL REINFORCEMENT SPACING, THEN LINTEL, BOND BEAM AND WALL ABOVE OPENING SHALL BE FILLED SOLID OVER OPENING WIDTH.
- 4.) IF THE CAST IN PLACE BEAM REQUIRES STIRRUPS, THEN USE 8" CMU INTERIOR WALL.
- 5.) THE TRUSS SPAN EQUALS THE SUM OF THE SPANS ON BOTH SIDES OF THE INTERIOR WALL.

# ROOF TRUSS ANCHOR

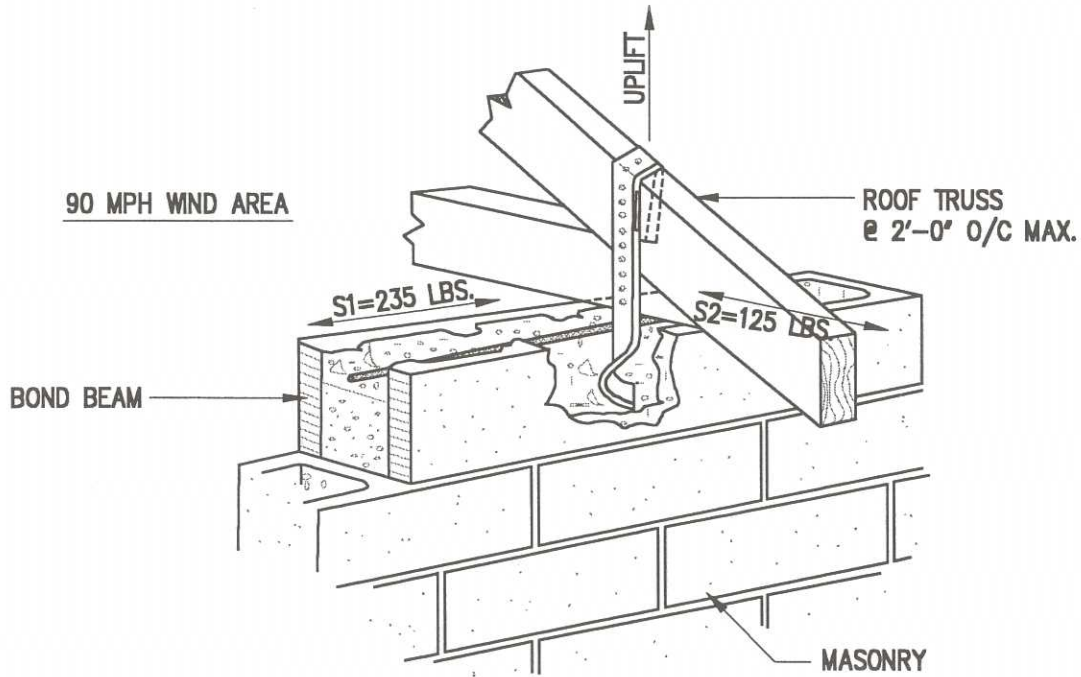

TRUSS ANCHOR LOAD SCHEDULE, LBS.		
ROOF TRUSS SPAN	NET UPLIFT INTERIOR ZONE	NET UPLIFT END ZONE (WITHIN 8' OF CORNER)
0' TO 20'	195	324
>20' TO 30'	262	456
>30' TO 40'	330	588

- NOTES: 1. FOR NO.1 HIP, CORNER JACKS AND END JACKS OF HIP ROOFS, USE TRUSS MANUFACTURERS LOADS OR SSTD 10. FOR GIRDER TRUSSES, USE TRUSS MANUFACTURERS LOADS.  
 2. FOR END JACKS, THE SIDEWALL LOADS AS DETERMINED BY THIS DOCUMENT MAY ALSO BE USED.

# ENTRY CONDITION DETAILS

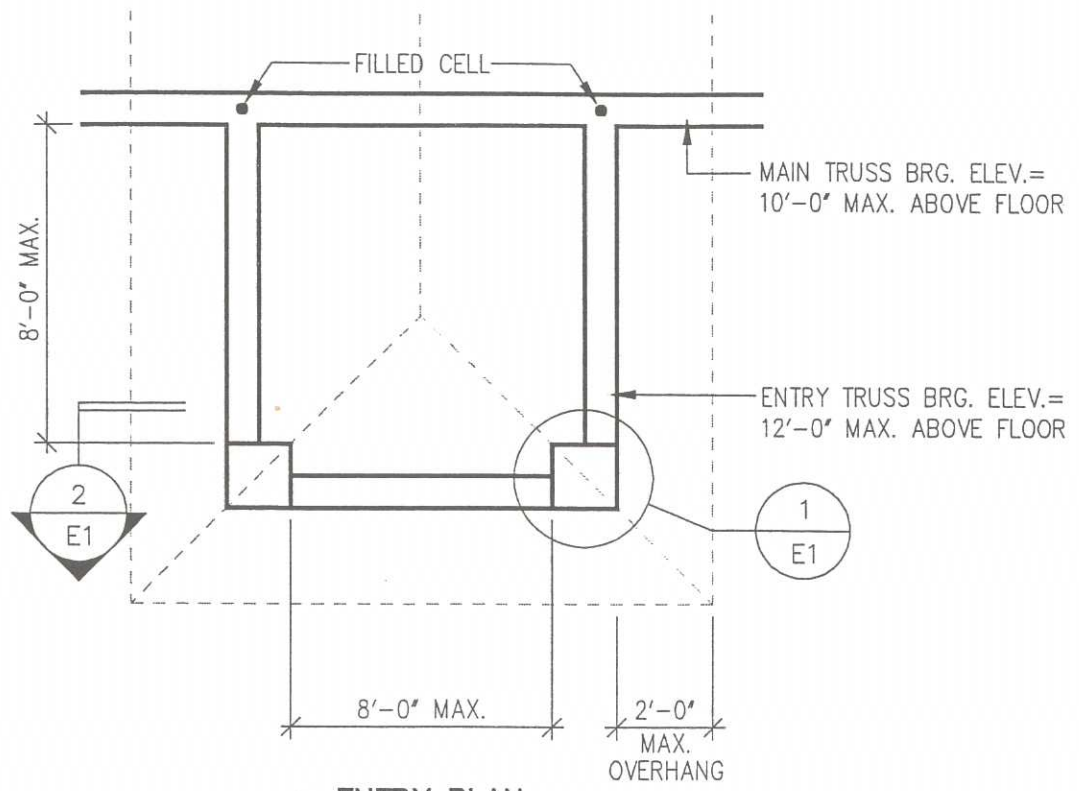

ENTRY PLAN

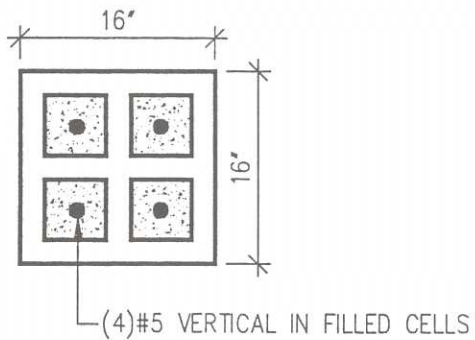
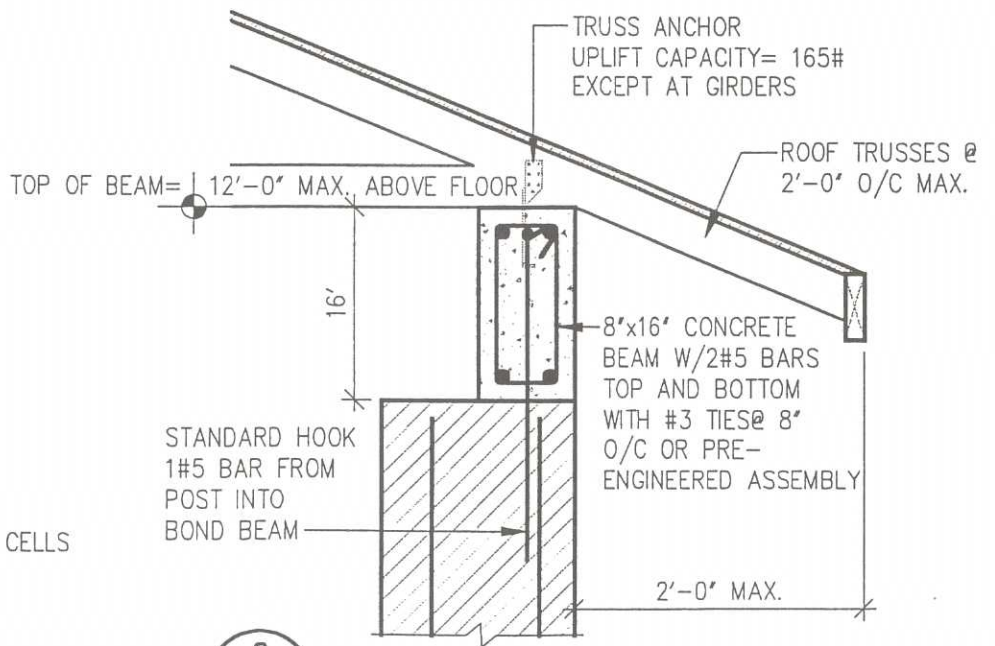

1/E1 MASONRY POST AT ENTRY

2/E1 PERIMETER BEAM FOR ENTRY

# VALLEY \ HIP DETAIL

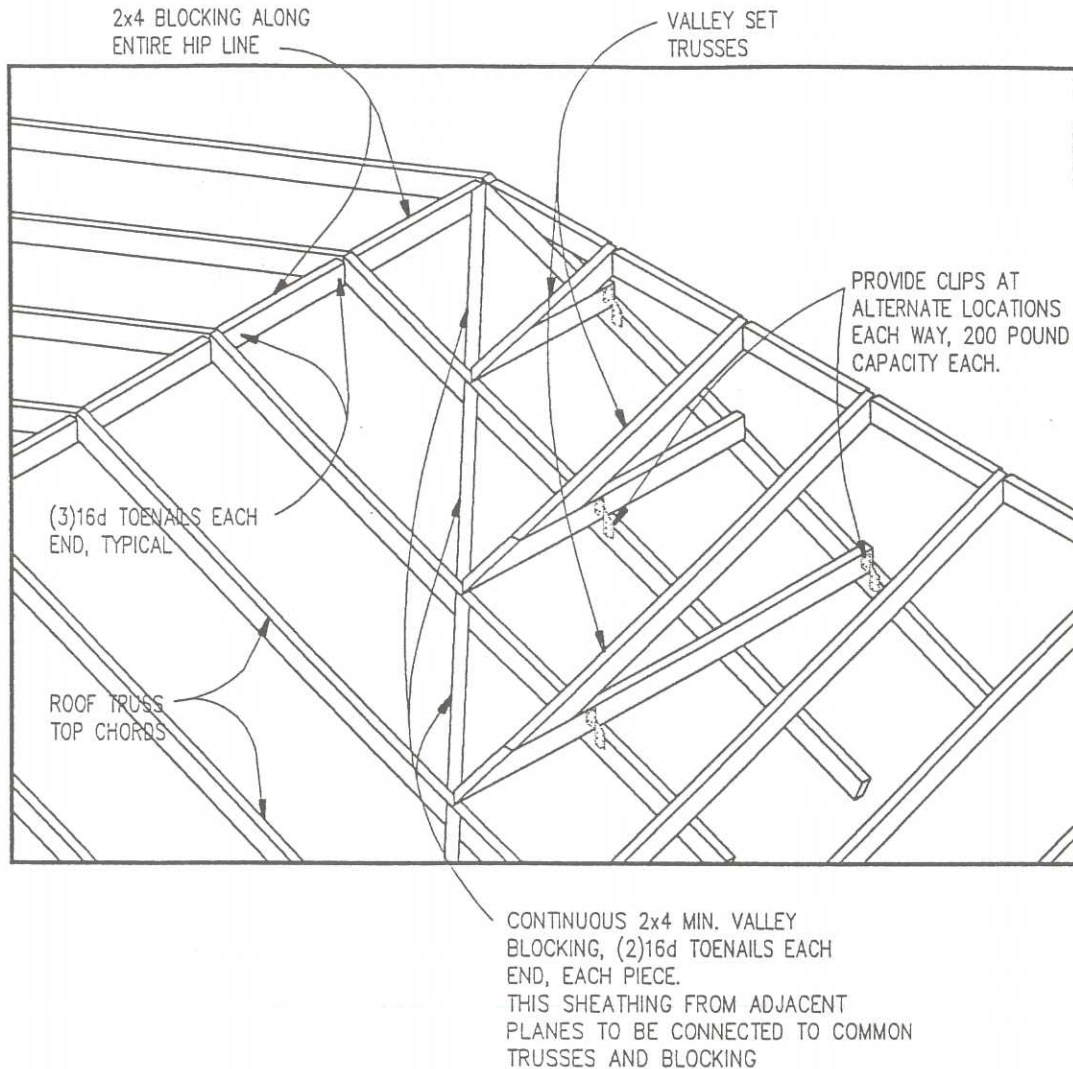

NOTE: SHEATHING MAY BE PROVIDED BETWEEN MAIN ROOF TRUSSES AND VALLEY SET TRUSSES.

THIS DETAIL APPLIES TO PRIMARY ROOF PLANES

# ROOF SHEATHING ATTACHMENT

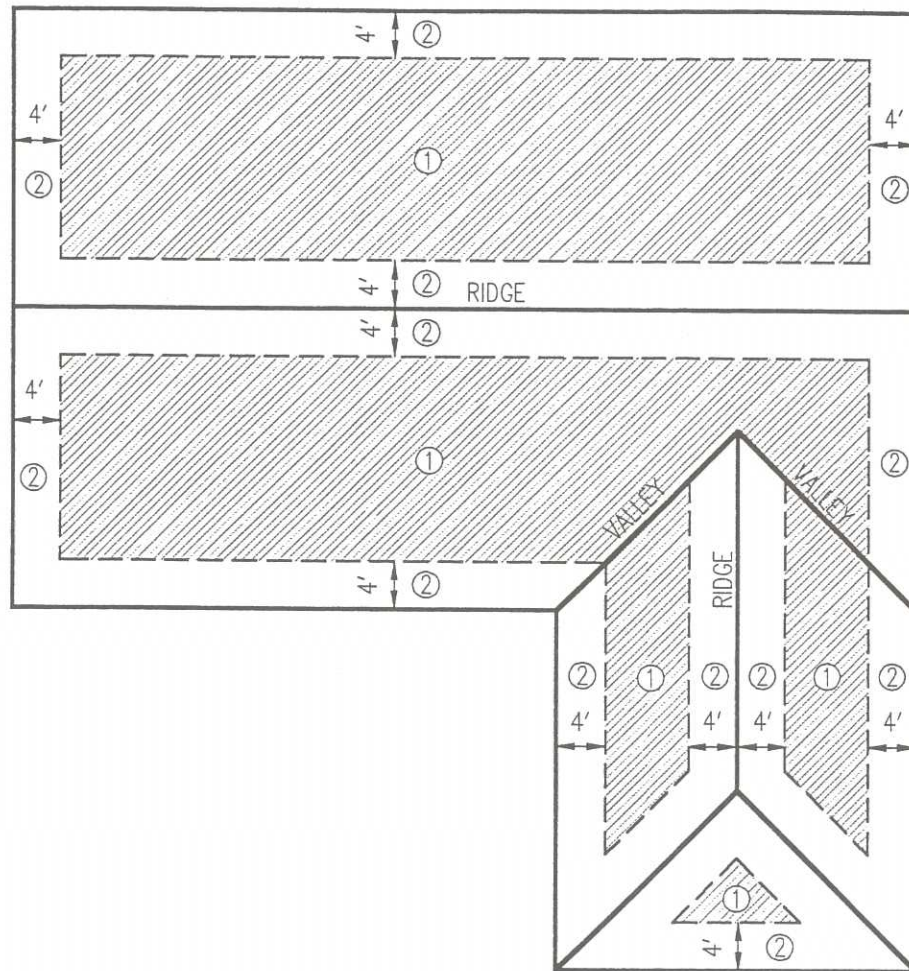

## SHEATHING NOTES:

ROOF SHEATHING TO BE WOOD STRUCTURAL PANEL RATED SHEATHING OR BETTER, EXPOSURE 1.

ROOF SHEATHING SHALL BE 7/16" THICKNESS OR GREATER.

ROOF TRUSSES @ 24" O/C MAXIMUM.

TRUSS TOP CHORDS SHALL HAVE A SPECIFIC GRAVITY OF  $G=0.46$  OR GREATER.

### NAILING PATTERN:

ZONE	SPACING
①	12" O/C MAX. IN FIELD, 6" O/C MAX PANEL EDGES.
②	6" O/C MAX. IN FIELD & AT EDGES.

NAILS SHALL BE: 8d COMMON FOR 7/16" & 15/32",  
10d COMMON FOR 1/2", 19/32", AND 5/8".

SEE ALSO SHEETS 90.7, 90.11, 90.18, 90.19, AND 90.20. FOR GABLE END REQUIREMENTS

# ALTERNATE GABLE END DETAIL

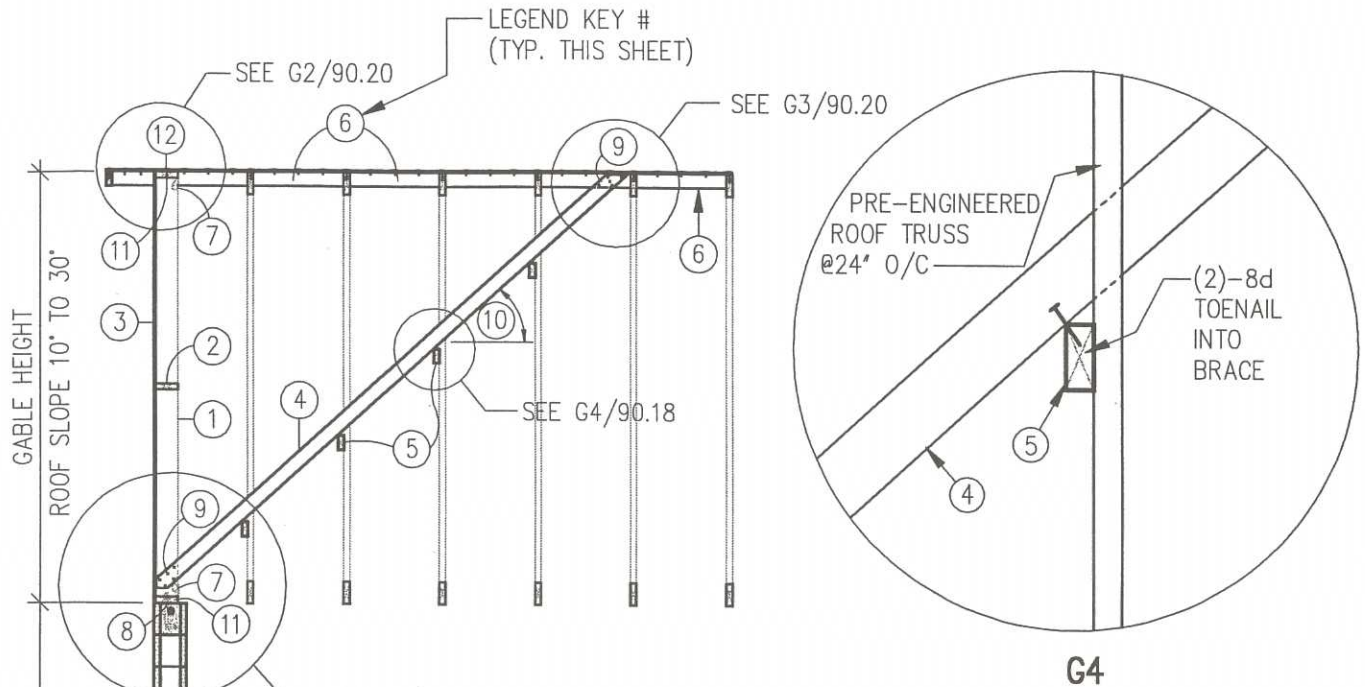

## LEGEND

- |   |  |
|---|--|
| ① | #2 2x6 @ 16' O/C   |
| ② | FULLY BLOCKED EDGES  |
| ③ | 7/16" MIN. RATED STRUCTURAL PANELS<br>8d NAILS 6" O/C @ EDGES,<br>12" O/C IN FIELD |
| ④ | DOUBLE 2x4 @ 32' O/C (1 EACH SIDE OF STUD)   |
| ⑤ | 2x4 CONTINUOUS NAILED TO TRUSS WEBS.   |
| ⑥ | 2x4 @ 32' O/C, ATTACH<br>SHEATHING TO 2x4 @ 6" O/C WITH 8d NAILS                   |
| ⑦ | UPLIFT STRAP = 100 LBS @<br>EACH STUD  |
| ⑧ | 1/2" $\phi$ BOLTS @ 48" O/C  |
| ⑨ | (5) 8d NAILS FOR EACH 2x4<br>OR 5/8" $\phi$ THRU-BOLT                              |
| ⑩ | ANGLE MAX. = 45°   |
| ⑪ | 2x6 P.T.   |
| ⑫ | 8d NAILS @ 6" O/C  |

# ALTERNATE GABLE END DETAIL

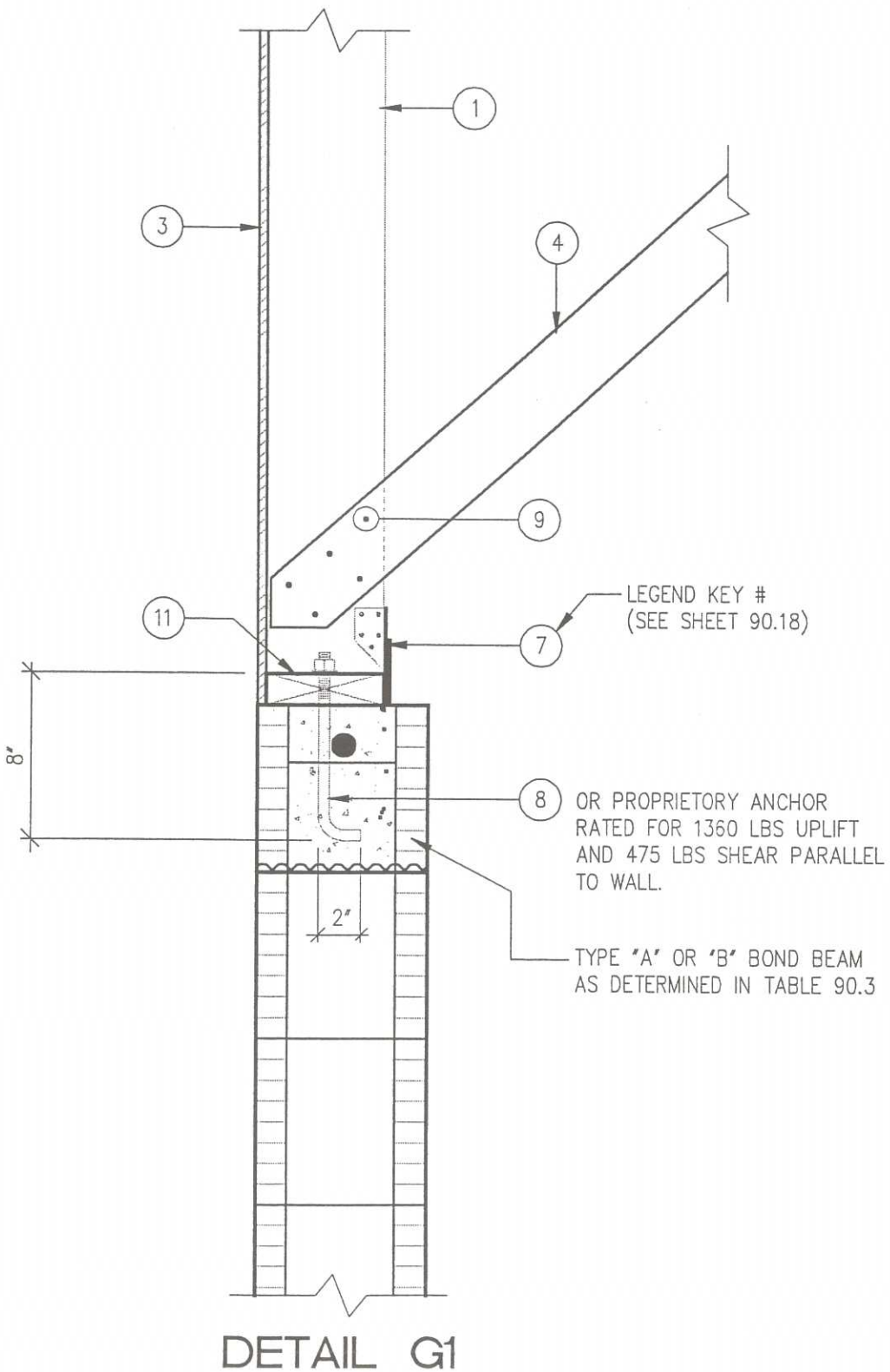

# ALTERNATE GABLE END DETAIL

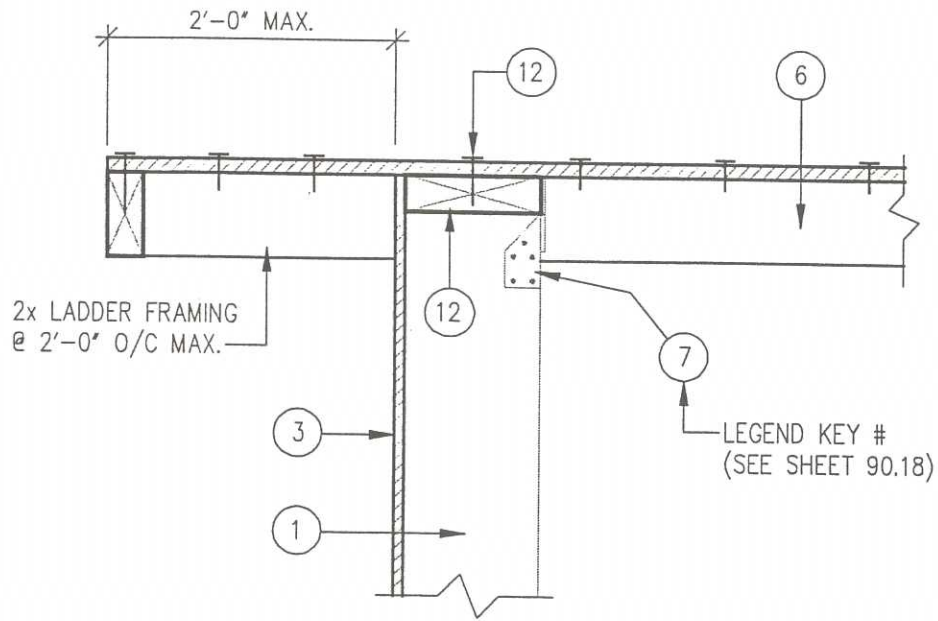

## DETAIL G2

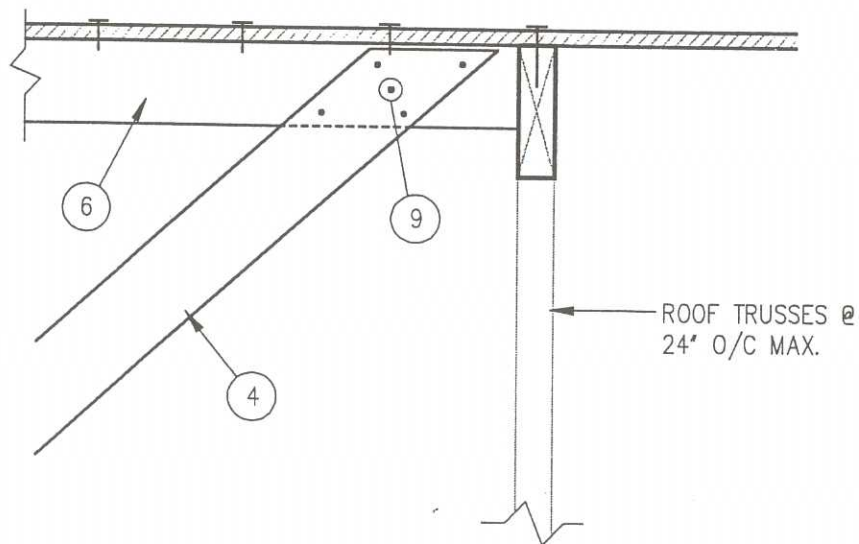

## DETAIL G3



# TABLE OF CONTENTS (100 mph)

## GUIDE TO CONCRETE MASONRY RESIDENTIAL CONSTRUCTION IN HIGH WIND AREAS 100 MPH DESIGN WIND SPEED VELOCITY

100.1	Table of Contents - 100 mph Design Wind Velocity
100.2	Vertical Reinforcement Details
100.3	Vertical Reinforcement Spacing
100.4	Gable Endwall Vertical Reinforcement
100.5	Shearwall Design Notes
100.6	Shearwall Proportioning Example
100.7	Shearwall Design Table
100.8	Lintel Types
100.9	Lintel Types - Continued
100.10	Lintel Schedule
100.11	Gable Endwall Details
100.12	Interior Bearing Wall Detail
100.13	Interior Bearing Wall Openings
100.14	Roof Truss Anchor
100.15	Entry Condition Details
100.16	Valley / Hip Detail
100.17	Roof Sheathing Attachment
100.18	Alternate Gable End Detail
100.19	Alternate Gable End Detail - Cont.
100.20	Alternate Gable End Detail - Cont.

# VERTICAL REINFORCEMENT DETAILS

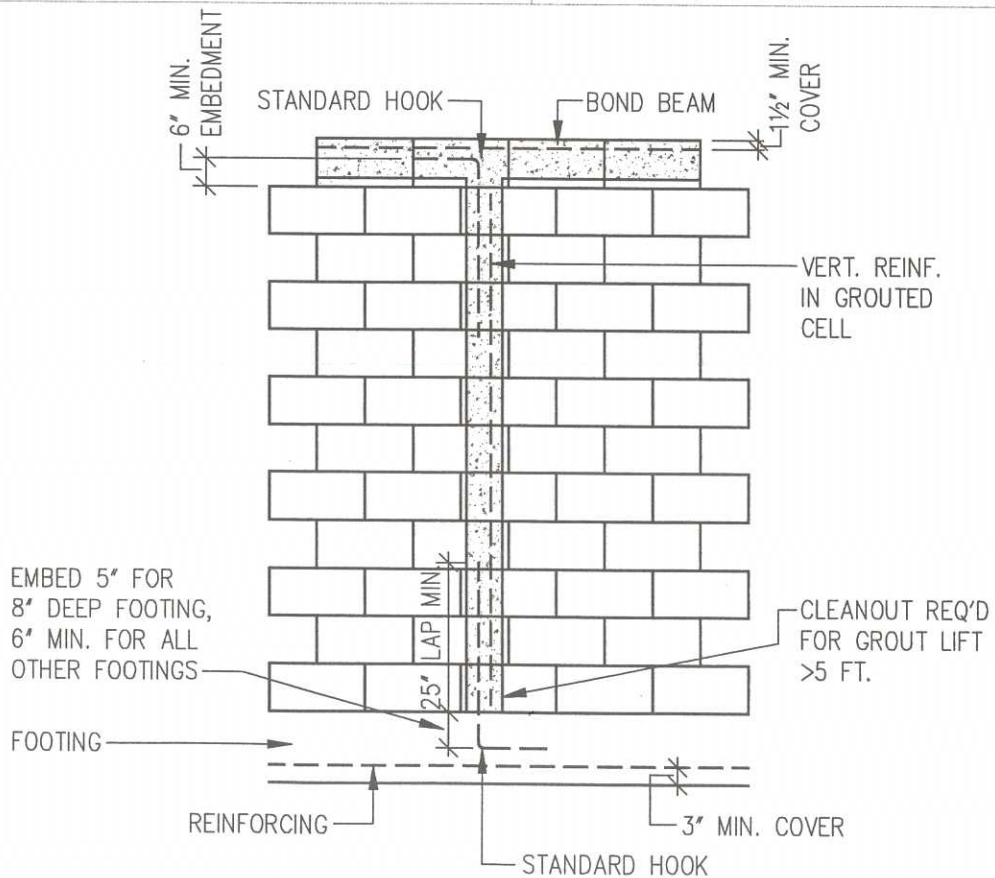
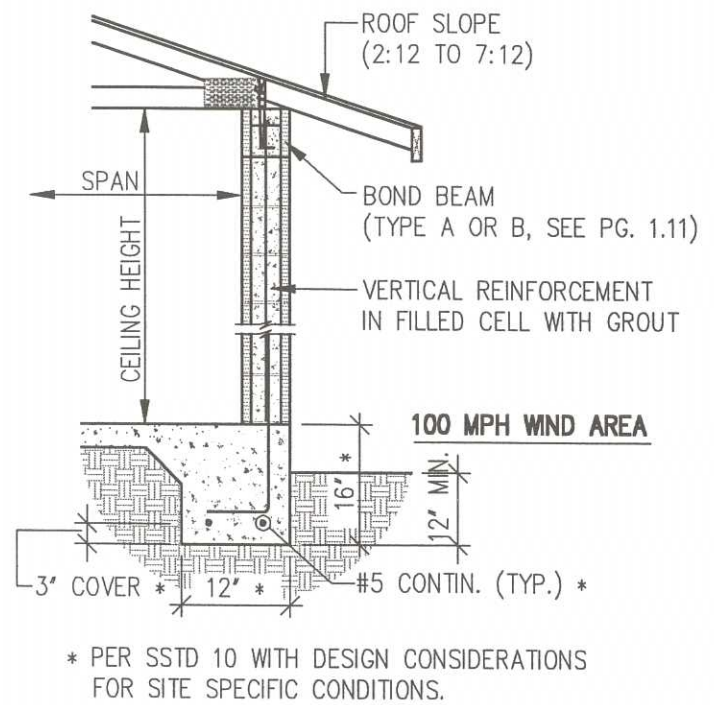
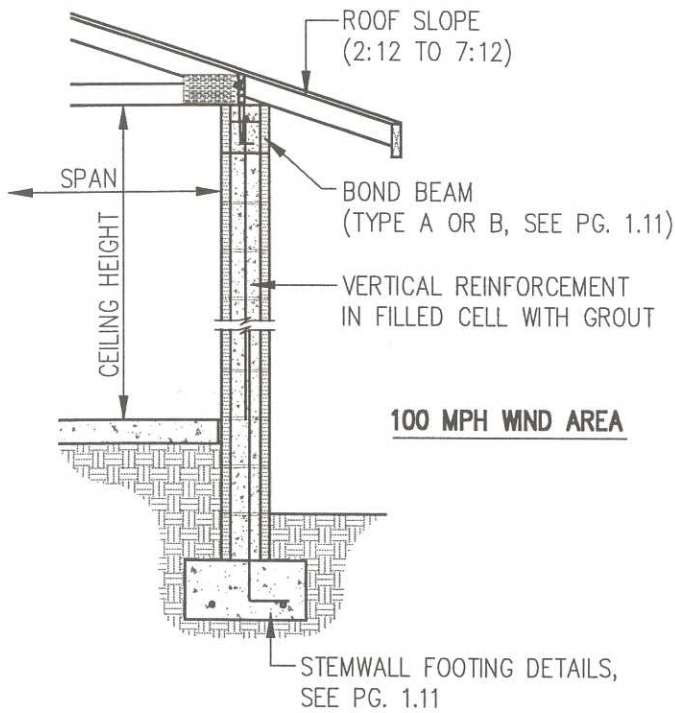

# VERTICAL REINFORCEMENT SPACING

MAXIMUM SPACING OF #5 BAR IN FILLED CELLS				
CEILING HEIGHT	BOND BEAM ⑤	SPAN 0'-20'	SPAN >20' TO 30'	SPAN >30' TO 40'
8'-0" OR LESS	A	12'-0"	12'-0"	10'-0"
	B	12'-0"	12'-0"	12'-0"
8'-8"	A	10'-8"	10'-8"	10'-0"
	B	10'-8"	10'-8"	10'-8"
9'-4"	A	8'-8"	8'-8"	8'-8"
	B	8'-8"	8'-8"	8'-8"
10'-0"	A	8'-0"	8'-0"	8'-0"
	B	8'-0"	8'-0"	8'-0"

NOTE:

1. PROVIDE ONE #5 BAR IN GROUTED CELL AT ALL WALL CORNERS AND INTERSECTIONS.
2. PROVIDE 1 #5 BAR IN GROUTED CELL AT EACH SIDE OF OPENINGS WIDER THAN 6'-0" AND AT EACH END OF SHEARWALL SEGMENTS. PROVIDE 2 #5 BARS ON EACH SIDE OF OPENINGS WIDER THAN 12'-0".
3. PROVIDE ONE #5 BAR IN GROUTED CELL AT ALL LOCATIONS WHERE GIRDERS OR GIRDER TRUSSES BEAR ON THE MASONRY WALL.
4. REDISTRIBUTE VERTICAL REINFORCEMENT ABOVE OPENINGS TO EACH SIDE OF OPENING. PROVIDE ½ OF THE REINFORCEMENT INTERRUPTED BY THE OPENING OR THE AMOUNT REQUIRED IN NOTE 2, WHICHEVER IS GREATER, ON EACH SIDE OF THE OPENING.
5. SEE PG. 1.11 FOR DESCRIPTION OF BOND BEAM TYPES 'A' AND 'B'.

# CONTINUOUS MASONRY GABLE END WALL VERTICAL REINFORCEMENT

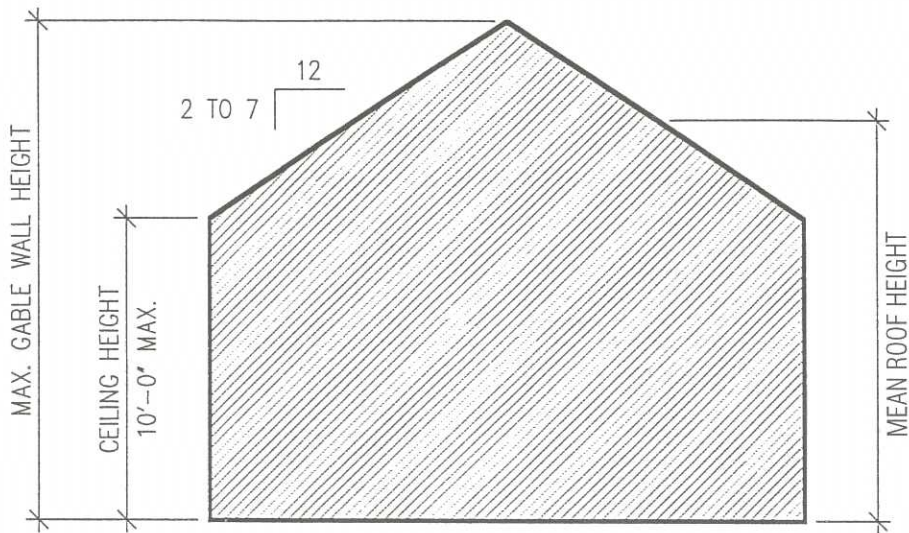

$$\text{MEAN ROOF HEIGHT} = \frac{\text{CEILING HEIGHT} + \text{MAX. GABLE HEIGHT}}{2}$$

TO DETERMINE THE VERTICAL SPACING REQUIRED FOR CONTINUOUS MASONRY GABLE WALLS, USE ONE OF THE FOLLOWING METHODS:

- METHOD 1.) DETERMINE THE MEAN ROOF HEIGHT OF THE GABLE END WALL AND USE THAT WALL HEIGHT IN THE TABLE BELOW TO OBTAIN THE VERTICAL REINFORCEMENT SPACING FOR THE ENTIRE WALL.
- METHOD 2.) DIVIDE THE GABLE WALL INTO SEGMENTS AND VARY THE VERTICAL SPACING BASED ON THE AVERAGE WALL HEIGHT IN EACH SEGMENT.

HEIGHT (EITHER BY METHOD 1 OR BY METHOD 2)	8' TO 10'	> 10' TO 13'	> 13' TO 16'	> 16' TO 19'	> 19' TO 22'
MAXIMUM SPACING OF 1#5 IN FILLED CELLS	8'-0"	4'-8"	2'-8"	2'-0"	0'-8"

NOTES ON SHEARWALL LENGTH DESIGN

- 1.) MINIMUM SHEARWALL SEGMENT LENGTH SHALL BE 2'-0".  
FILLED CELL WITH 1#5 BAR REQUIRED AT EACH END OF SHEARWALL SEGMENT.
- 2.) PORTIONS OF WALLS WITH OPENINGS SHALL NOT BE CONSIDERED PART OF THE SHEARWALL LENGTH.
- 3.) THE CUMULATIVE SHEARWALL LENGTH FOR EACH SIDE OF THE BUILDING MUST BE EQUAL TO OR GREATER THAN THE TABULATED SHEARWALL LENGTH REQUIRED.

\* DOES NOT HAVE TO BE CONTINUOUS, AS LONG AS TOTAL LENGTH OF SEPARATE SEGMENTS MEETS THE SHEARWALL LENGTH REQUIREMENTS.

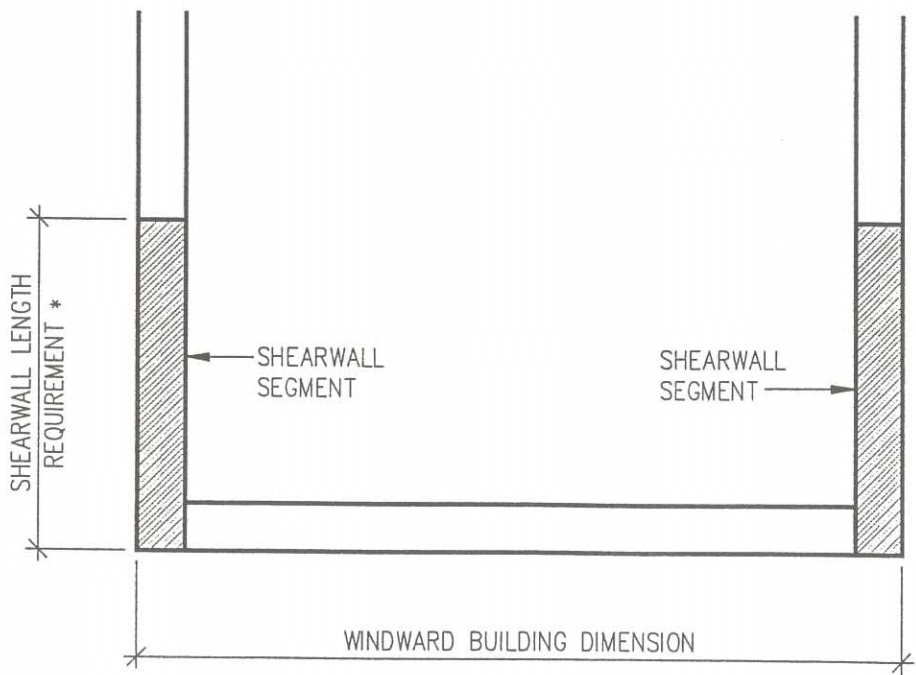

# SHEARWALL PROPORTIONING EXAMPLE

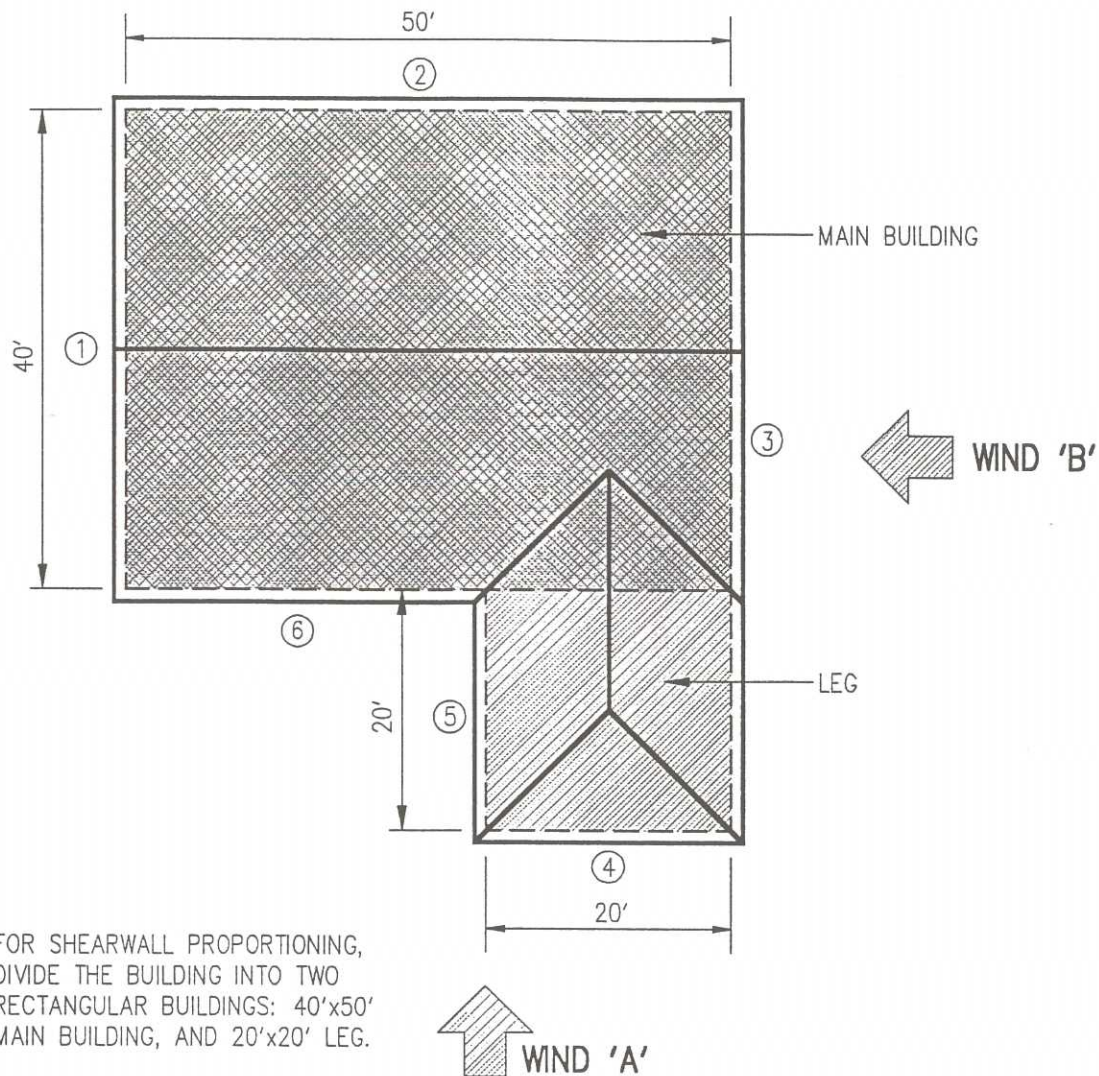

## WIND 'A'

TO DETERMINE THE AMOUNT OF SHEARWALL REQUIRED IN ①, ③ AND ⑤, THE "WINDWARD MAIN BUILDING DIMENSION" IS 50'. PER THE TABLE ON 100.4, THE REQUIRED SHEARWALL LENGTH IS 1'-10". HOWEVER, THE MINIMUM SHEARWALL SEGMENT LENGTH IS 2'-0". THEREFORE PROVIDE A 2'-0" SEGMENT IN ① AND A 2'-0" SEGMENT IN ③. ⑤ DOES NOT HAVE A SHEARWALL REQUIREMENT BECAUSE THE WINDWARD BUILDING AREA OF THE MAIN BUILDING WAS NOT INCREASED BY THE LEG.

## WIND 'B'

TO DETERMINE THE AMOUNT OF SHEARWALL REQUIRED IN ②, ④ AND ⑥, THE LENGTH REQUIRED IN ② AND THE MAIN BUILDING PORTION OF ⑥ IS BASED UPON 40' FOR A GABLE END. THE LENGTH REQUIRED FOR ④ AND THE LEG PORTION OF ⑥ IS BASED UPON 20'. THE SHEARWALL LENGTH IN ⑥ SHALL BE EQUAL TO THE SUM OF ② AND ④. FOR THIS EXAMPLE, ② REQUIRES 2'-5", ④ REQUIRES 0'-6" (2'-0" MIN.) AND ⑥ REQUIRES 2'-11" (2'-5" + 0'-6").

# SHEARWALL DESIGN TABLE



## 100 MPH WIND AREA

REQUIRED SHEARWALL LENGTH (2:12 TO 7:12 ROOF SLOPE)

WINDWARD BUILDING DIMENSION	SHEARWALL LENGTH REQUIRED (EACH SIDE) OF BUILDING (EXCEPT GABLE END WINDS)	SHEARWALL LENGTH REQUIRED (EACH SIDE) OF BUILDING PERPENDICULAR TO GABLE END
10' TO 20'	0'-6" *	0'-8" *
>20' TO 30'	0'-11" *	1'-6" *
>30' TO 40'	1'-5" *	2'-5"
>40' TO 50'	1'-10" *	
>50' TO 60'	2'-3"	
>60' TO 70'	2'-8"	
>70' TO 80'	3'-1"	
* 2'-0" MINIMUM SHEARWALL SEGMENT LENGTH		

NOTE: MAXIMUM SHEARWALL PIER HEIGHT= 6'-0" FOR 2'-0" LENGTH. A MAXIMUM SHEARWALL PIER HEIGHT OF 8'-8" IS ALLOWED FOR SHEARWALL LENGTHS OF 2'-8" OR GREATER.

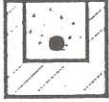
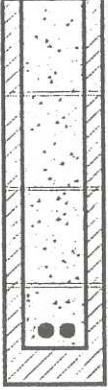
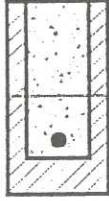
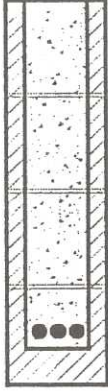
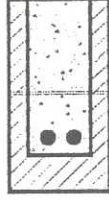
# LINTEL TYPES

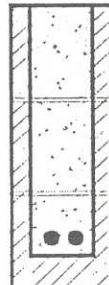
 <p>'A2'</p> <p>8x8 MASONRY LINTEL W/1#5 BOTTOM FILLED SOLID WITH GROUT</p>	 <p>'D'</p> <p>8x32 MASONRY LINTEL W/2#5 BOTTOM FILLED SOLID WITH GROUT</p>
 <p>'B2'</p> <p>8x16 MASONRY LINTEL W/1#5 BOTTOM FILLED SOLID WITH GROUT</p>	 <p>'D2'</p> <p>8x32 MASONRY LINTEL W/3#5 BOTTOM FILLED SOLID WITH GROUT</p>
 <p>'B3'</p> <p>8x16 MASONRY LINTEL W/2#5 BOTTOM FILLED SOLID WITH GROUT</p>	 <p>'E'</p> <p>8x40 MASONRY LINTEL W/3#5 BOTTOM FILLED SOLID WITH GROUT</p>
 <p>'C'</p> <p>8x24 MASONRY LINTEL W/1#5 BOTTOM FILLED SOLID WITH GROUT</p>	
 <p>'C2'</p> <p>8x24 MASONRY LINTEL W/2#5 BOTTOM FILLED SOLID WITH GROUT</p>	



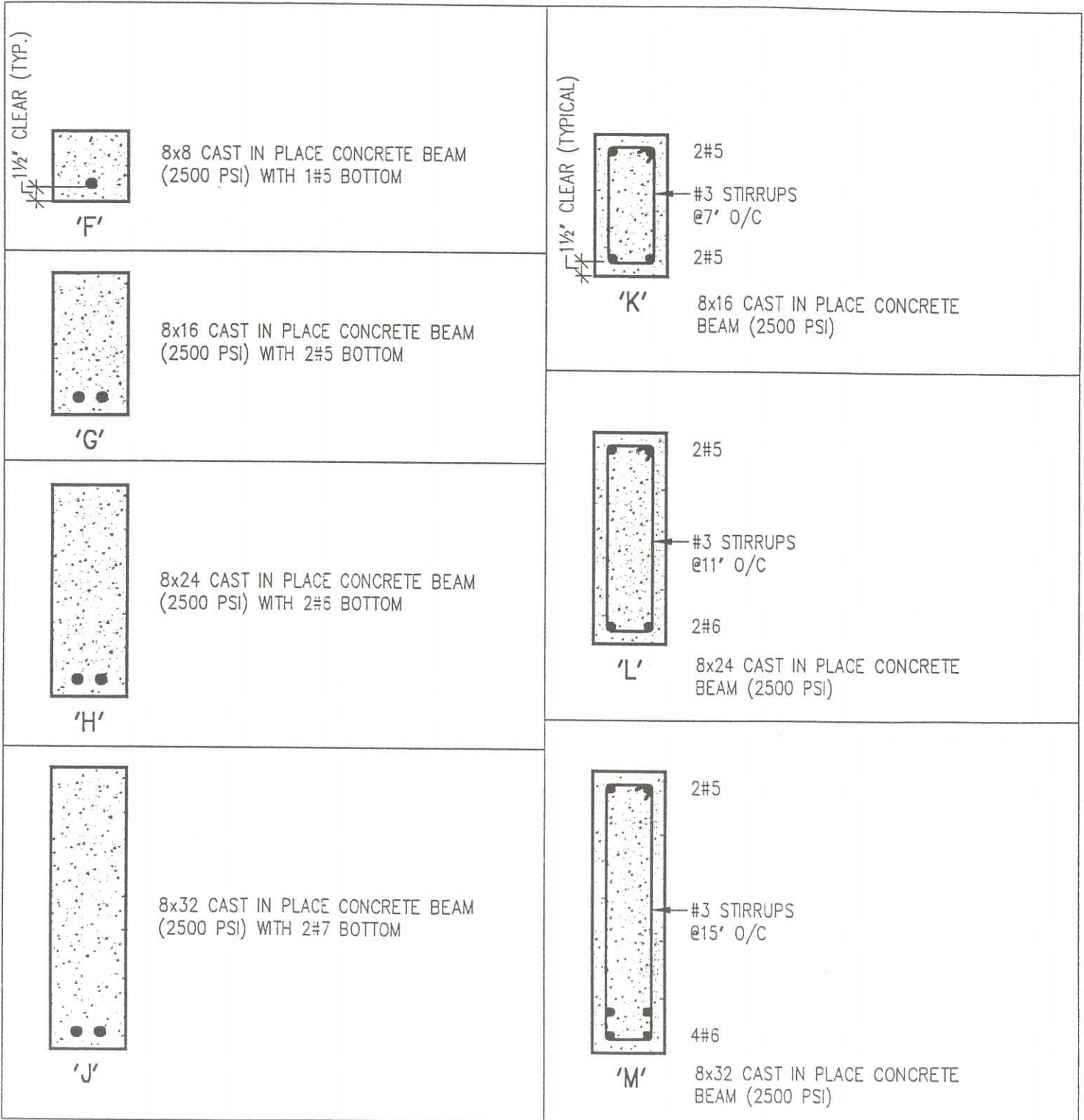

# LINTEL SCHEDULE

LINTEL SCHEDULE				
MAX. CLEAR OPENING WIDTH	ROOF TRUSS SPAN	PRECAST LINTEL ALLOWABLE LOAD (PLF) ③	MASONRY LINTEL	CAST IN PLACE BEAMS
UP TO 3'-0"	0' TO 20'	650	A2	F
	>20' TO 30'	875	A2	G
	>30' TO 40'	1,100	A2	G
>3'-0" TO 6'-0"	0' TO 20'	650	B2	G
	>20' TO 30'	875	B2	G
	>30' TO 40'	1,100	B2	H OR K
>6'-0" TO 9'-0"	0' TO 20'	650	B3	H OR K
	>20' TO 30'	875	C	H OR K
	>30' TO 40'	1,100	C2	J OR K
>9'-0" TO 12'-0"	0' TO 20'	650	C2	H OR K
	>20' TO 30'	875	C2	J OR L
	>30' TO 40'	1,100	D	L
>12'-0" TO 15'-0"	0' TO 20'	650	D	J OR L
	>20' TO 30'	875	D	L
	>30' TO 40'	1,100	D2	M
>15'-0" TO 18'-0"	0' TO 20'	650	D	L
	>20' TO 30'	875	E	M
	>30' TO 40'	1,100	E	M

NOTE:

- MUST MAINTAIN CONTINUITY OF BOND BEAM AT TOP OF WALL.
- IF MASONRY OPENING EXCEEDS SCHEDULED VERTICAL REINFORCEMENT SPACING, THEN LINTEL, BOND BEAM AND WALL ABOVE OPENING SHALL BE FILLED SOLID OVER OPENING WIDTH.
- RATED CAPACITY OF PRECAST LINTEL BY ITSELF OR THROUGH COMPOSITE ACTION WITH OTHER ELEMENTS.

# GABLE ENDWALL DETAILS

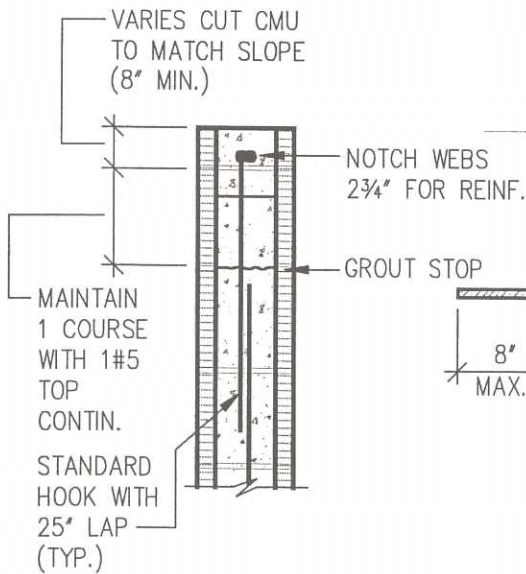
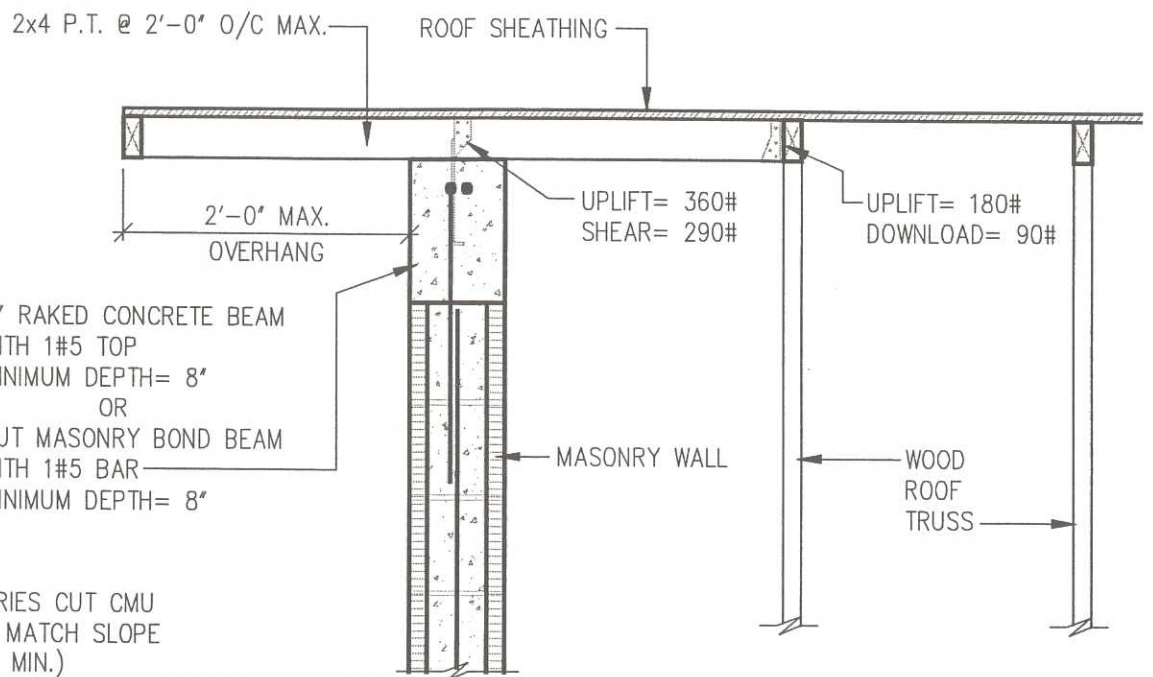
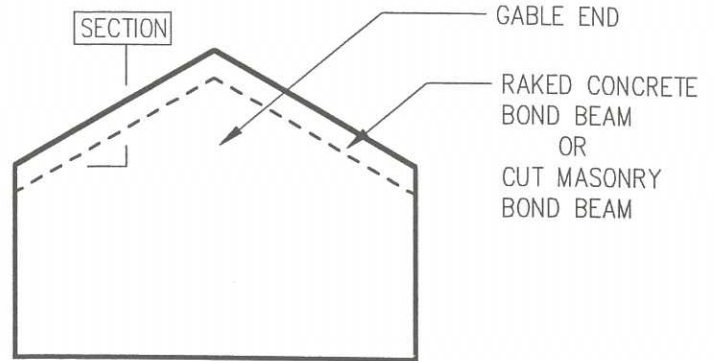

ALTERNATE CUT MASONRY BOND BEAM

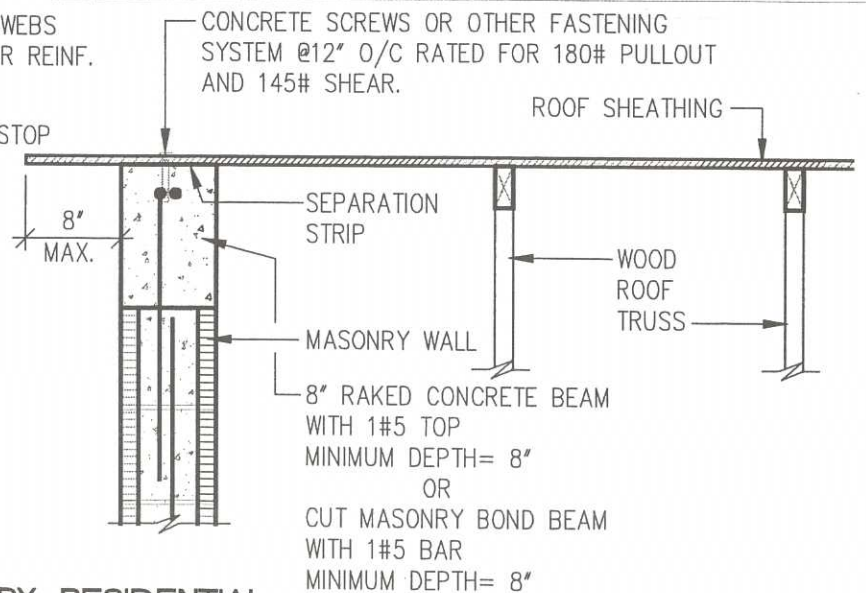

# INTERIOR BEARING WALL DETAIL

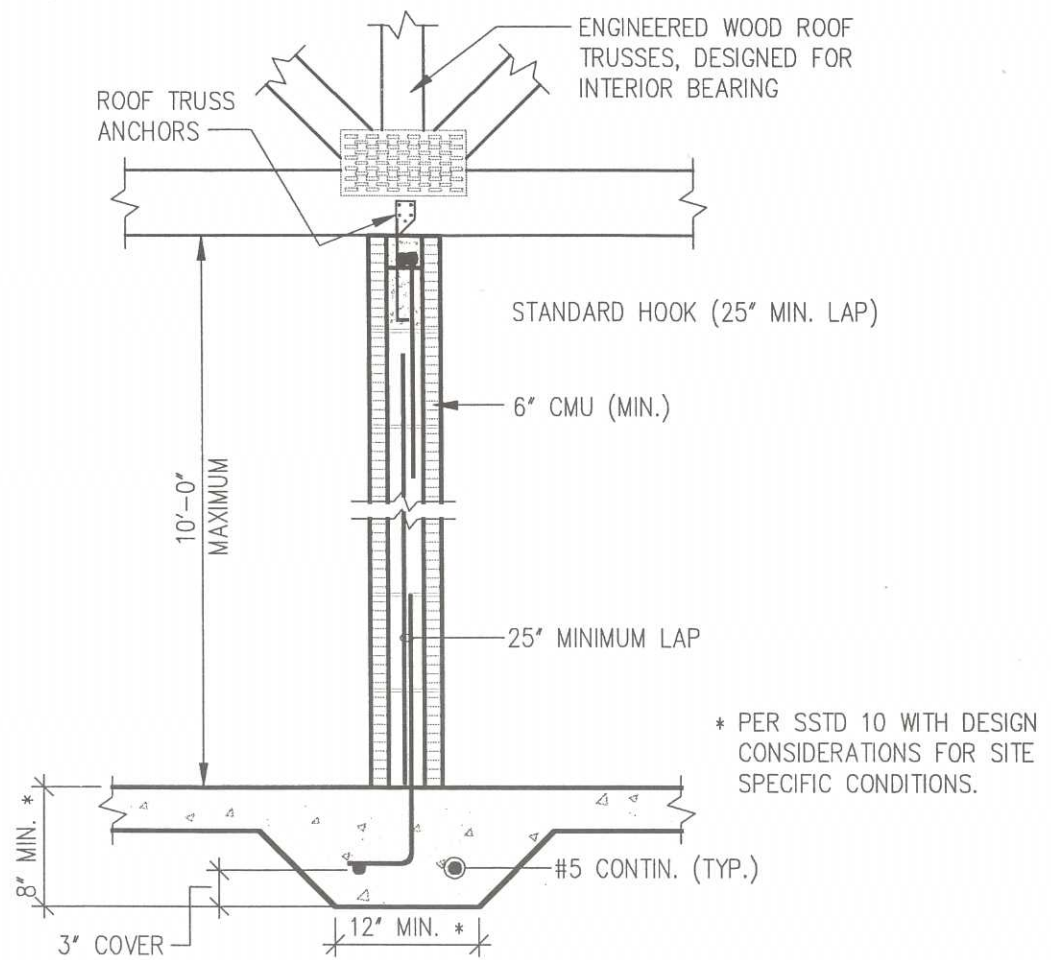

SPAN	ROOF TRUSS ANCHOR NET UPLIFT (LBS) (TRUSSES @ 24")		MAX. SPACING OF #5 BAR IN FILLED CELL	
	INTERIOR ZONE	END ZONE (TRUSSES 8' OR CLOSER TO OUTSIDE OF ENDWALL)	BOND BEAM 'A' (6x8)	BOND BEAM 'B' (6x16)
10'	94	164	13'-4"	24'-0"
20'	188	328	10'-0"	18'-8"
30'	282	492	8'-0"	16'-0"
40'	376	656	7'-4"	14'-8"
50'	470	820	6'-0"	13'-4"
60'	564	984	5'-4"	12'-8"
70'	658	1148	4'-8"	12'-0"
80'	752	1312	4'-0"	10'-8"

**NOTE:**

1. PROVIDE ONE #5 BAR IN GROUTED CELL AT CORNERS AND INTERSECTIONS.
2. PROVIDE 1 #5 BAR IN GROUTED CELL AT EACH SIDE OF OPENINGS WIDER THAN 6'-0" AND 2 #5 BARS ON EACH SIDE OF OPENINGS WIDER THAN 12'-0".
3. PROVIDE ONE #5 BAR IN GROUTED CELL AT ALL LOCATIONS WHERE GIRDERS OR GIRDER TRUSSES BEAR ON THE MASONRY WALL.
4. INTERIOR BEARING WALLS MAY BE CONSTRUCTED OF ALTERNATE MATERIALS IN ACCORDANCE WITH ACCEPTED STANDARDS.

# INTERIOR BEARING WALL OPENINGS

LINTEL SCHEDULE FOR 6' CMU INTERIOR WALLS				
TRUSS SPAN ⑤	OPENING WIDTH	PRECAST LINTEL ALLOWABLE LOAD (PLF)	MASONRY LINTEL	CAST IN PLACE BEAMS ④
0' TO 20'	0' TO 6' > 6' TO 9' > 6' TO 12'	617	B2 B3 C2	G H OR K J OR L
>20' TO 30'	0' TO 6' > 6' TO 9' > 6' TO 12'	842	B2 C D	H OR K J OR K L
>30' TO 40'	0' TO 6' > 6' TO 9' > 6' TO 12'	1067	C D E	H OR K J OR K L
>40' TO 50'	0' TO 6' > 6' TO 9' > 6' TO 12'	1292	C D E	J OR K K L
>50' TO 60'	0' TO 6' > 6' TO 9' > 6' TO 12'	1517	C E —	J OR K L L
>60' TO 70'	0' TO 6' > 6' TO 9' > 6' TO 12'	1742	D E —	K L M
>70' TO 80'	0' TO 6' > 6' TO 9' > 6' TO 12'	1967	D — —	K L M

**NOTE:**

- 1.) MUST MAINTAIN CONTINUITY OF BOND BEAM.
- 2.) LINTEL TYPES REFERENCED ARE SIMILAR TO 8' LINTELS (100.8) EXCEPT THE BEAM WIDTH IS 6'.
- 3.) IF MASONRY OPENING EXCEEDS SCHEDULED VERTICAL REINFORCEMENT SPACING, THEN LINTEL, BOND BEAM AND WALL ABOVE OPENING SHALL BE FILLED SOLID OVER OPENING WIDTH.
- 4.) IF THE CAST IN PLACE BEAM REQUIRES STIRRUPS, THAN USE 8' CMU INTERIOR WALL.
- 5.) THE TRUSS SPAN EQUALS THE SUM OF THE SPANS ON BOTH SIDES OF THE INTERIOR WALL.

# ROOF TRUSS ANCHOR

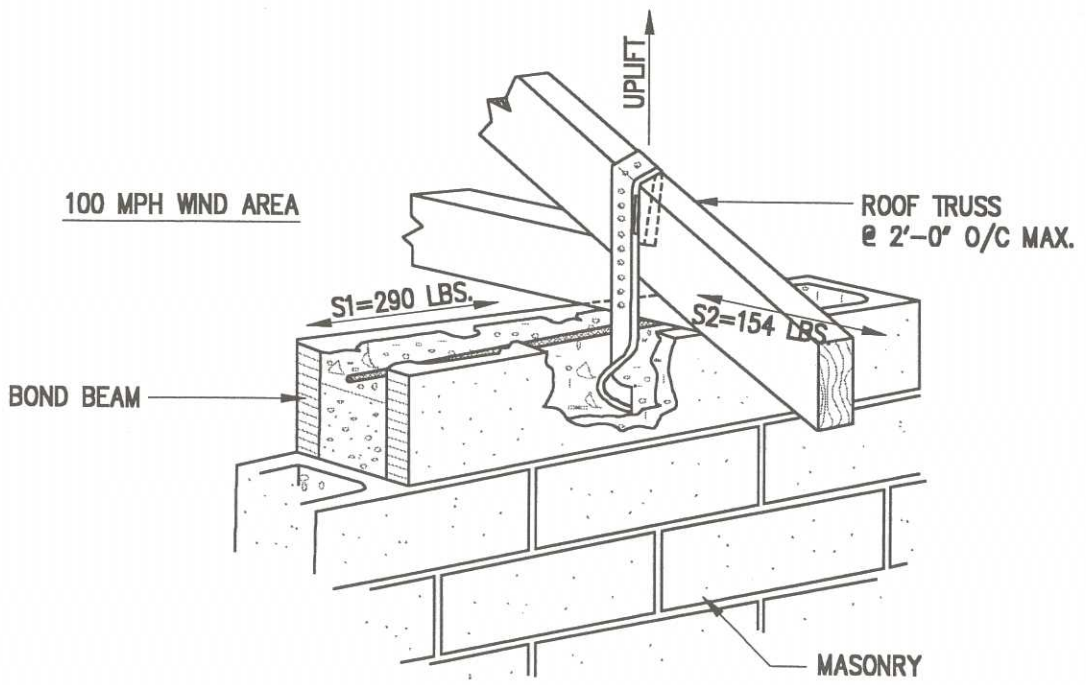

TRUSS ANCHOR LOAD SCHEDULE, LBS.		
ROOF TRUSS SPAN	NET UPLIFT INTERIOR ZONE	NET UPLIFT END ZONE (WITHIN 8' OF CORNER)
0' TO 20'	293	452
>20' TO 30'	398	637
>30' TO 40'	503	822

- NOTES: 1. FOR NO.1 HIP, CORNER JACKS AND END JACKS OF HIP ROOFS, USE TRUSS MANUFACTURERS LOADS OR SSTD 10. FOR GIRDER TRUSSES, USE TRUSS MANUFACTURERS LOADS.  
 2. FOR END JACKS, THE SIDEWALL LOADS AS DETERMINED BY THIS DOCUMENT MAY ALSO BE USED.

# ENTRY CONDITION DETAILS

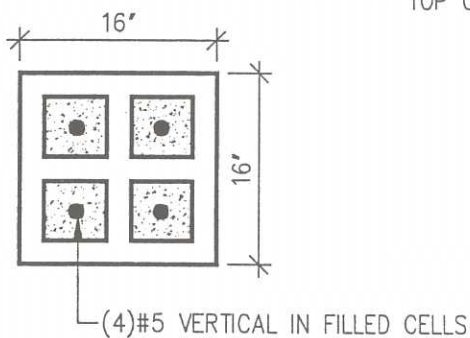
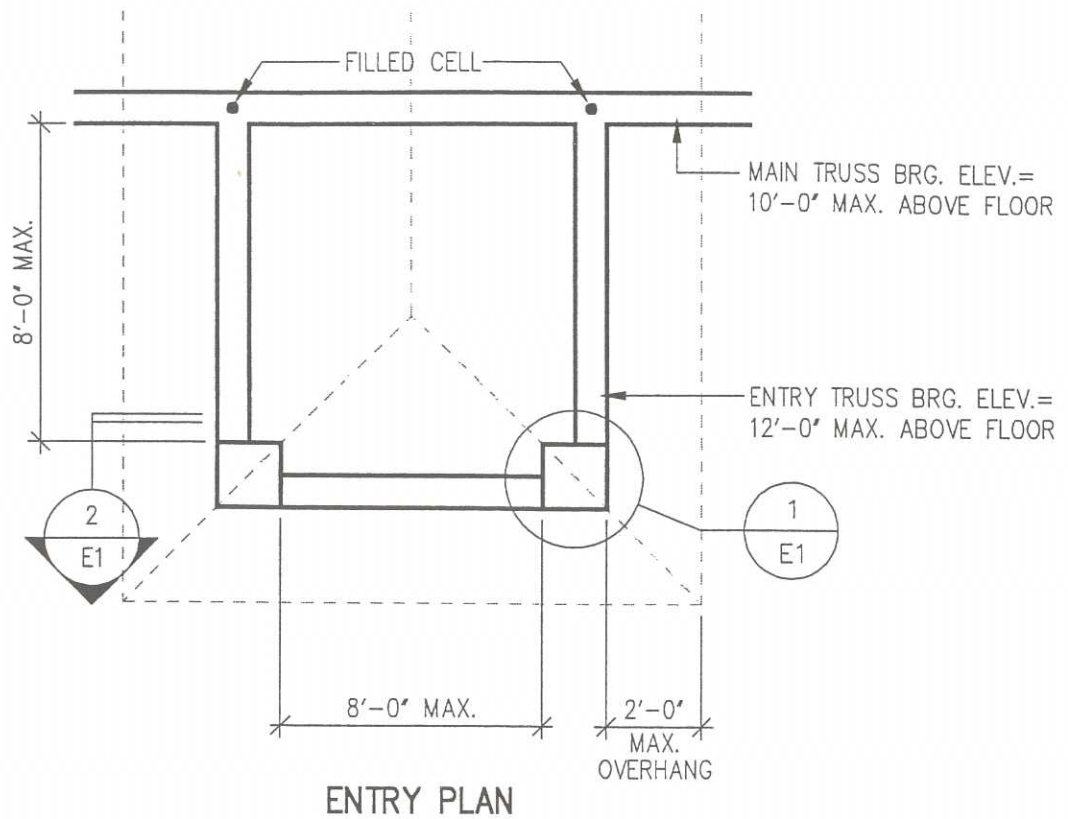

1  
E1 MASONRY POST AT ENTRY

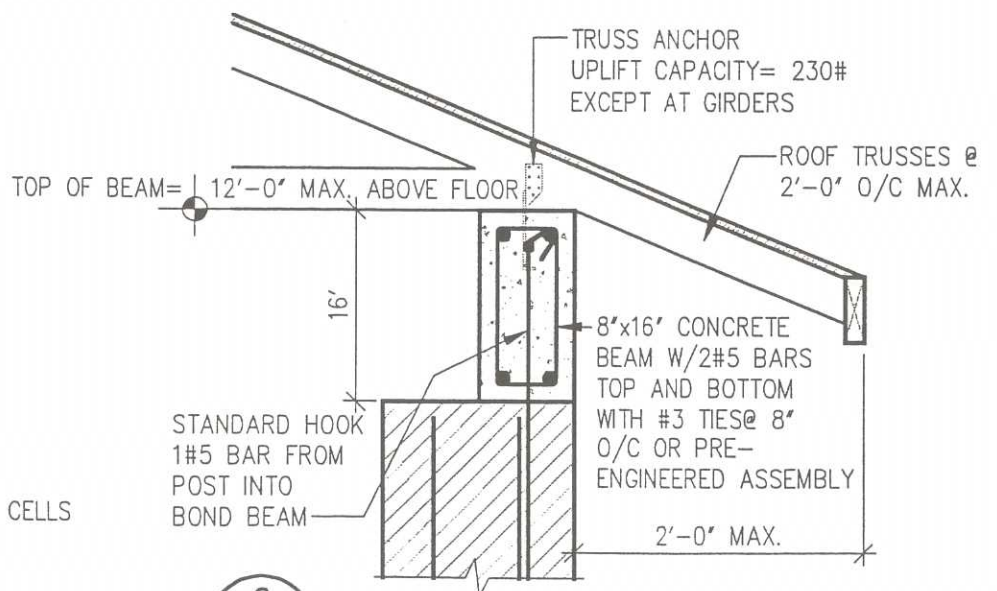

2  
E1 PERIMETER BEAM FOR ENTRY

# VALLEY \ HIP DETAIL

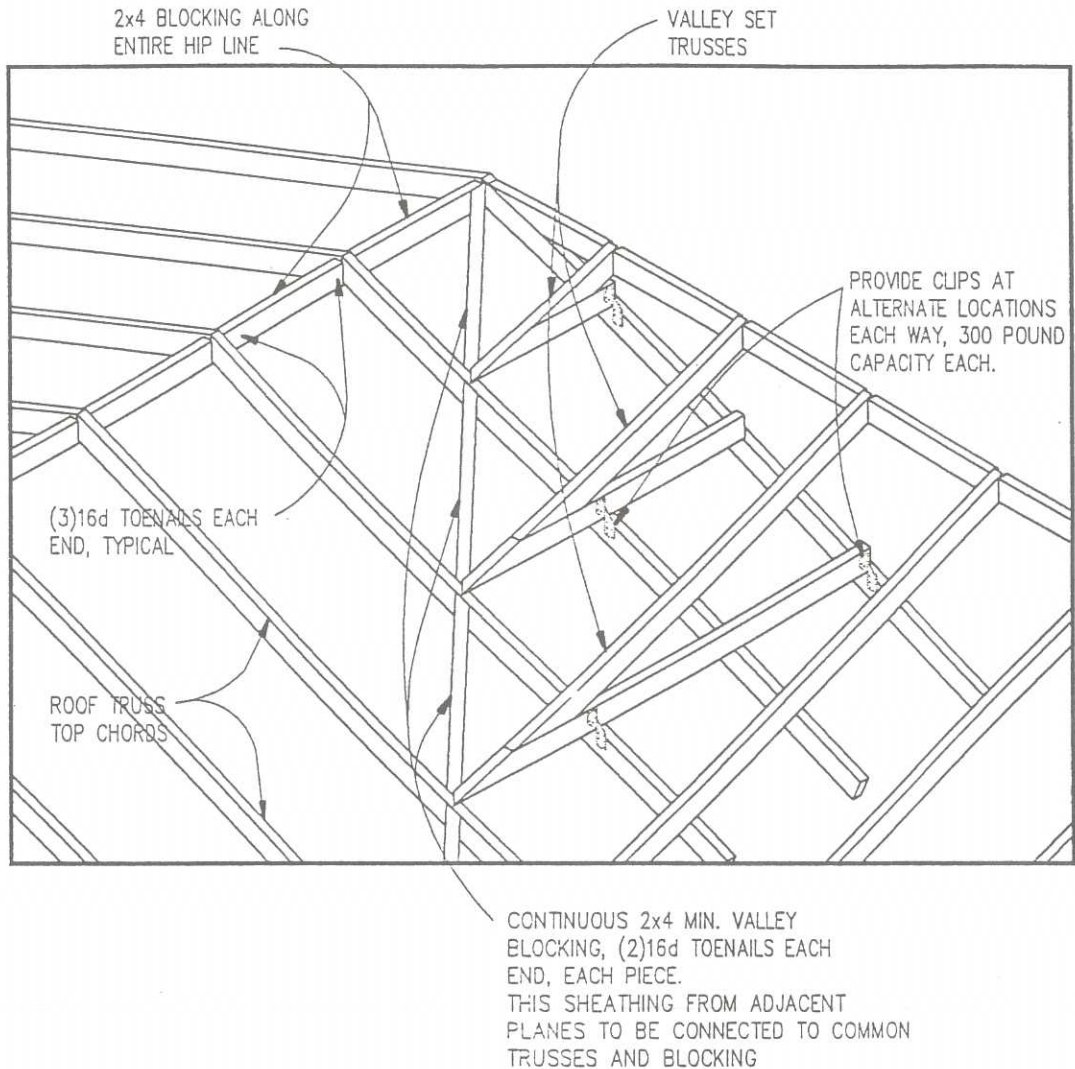

NOTE: SHEATHING MAY BE PROVIDED BETWEEN MAIN ROOF TRUSSES AND VALLEY SET TRUSSES.

THIS DETAIL APPLIES TO PRIMARY ROOF PLANES



# ROOF SHEATHING ATTACHMENT

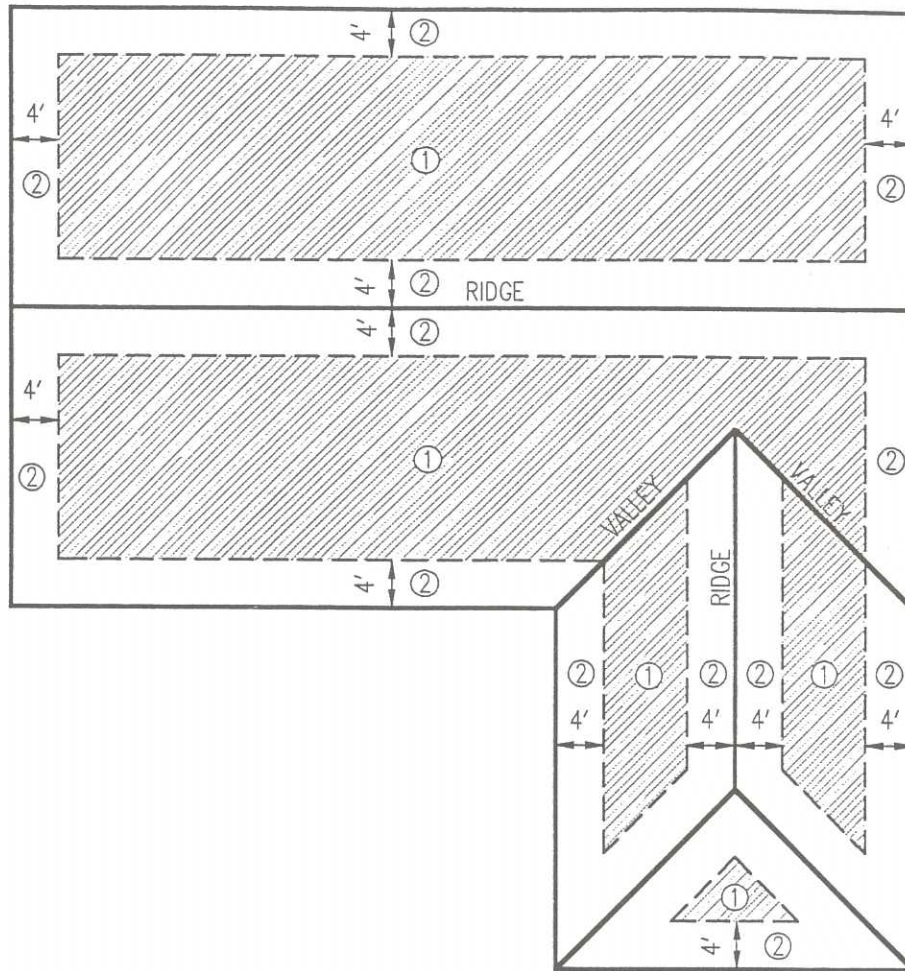

## SHEATHING NOTES:

ROOF SHEATHING TO BE WOOD STRUCTURAL PANEL RATED SHEATHING OR BETTER, EXPOSURE 1.

ROOF SHEATHING SHALL BE 7/16" THICKNESS OR GREATER.

ROOF TRUSSES @ 24" O/C MAXIMUM.

TRUSS TOP CHORDS SHALL HAVE A SPECIFIC GRAVITY OF G=0.46 OR GREATER.

### NAILING PATTERN:

ZONE	SPACING
①	12" O/C MAX. IN FIELD, 6" O/C MAX PANEL EDGES.
②	6" O/C MAX. IN FIELD & AT EDGES.

NAILS SHALL BE: 8d COMMON FOR 7/16" & 15/32",  
10d COMMON FOR 1/2", 19/32", AND 5/8".

SEE ALSO SHEETS 100.7, 100.11, 100.18, 100.19, AND 100.20. FOR GABLE END REQUIREMENTS

# ALTERNATE GABLE END DETAIL

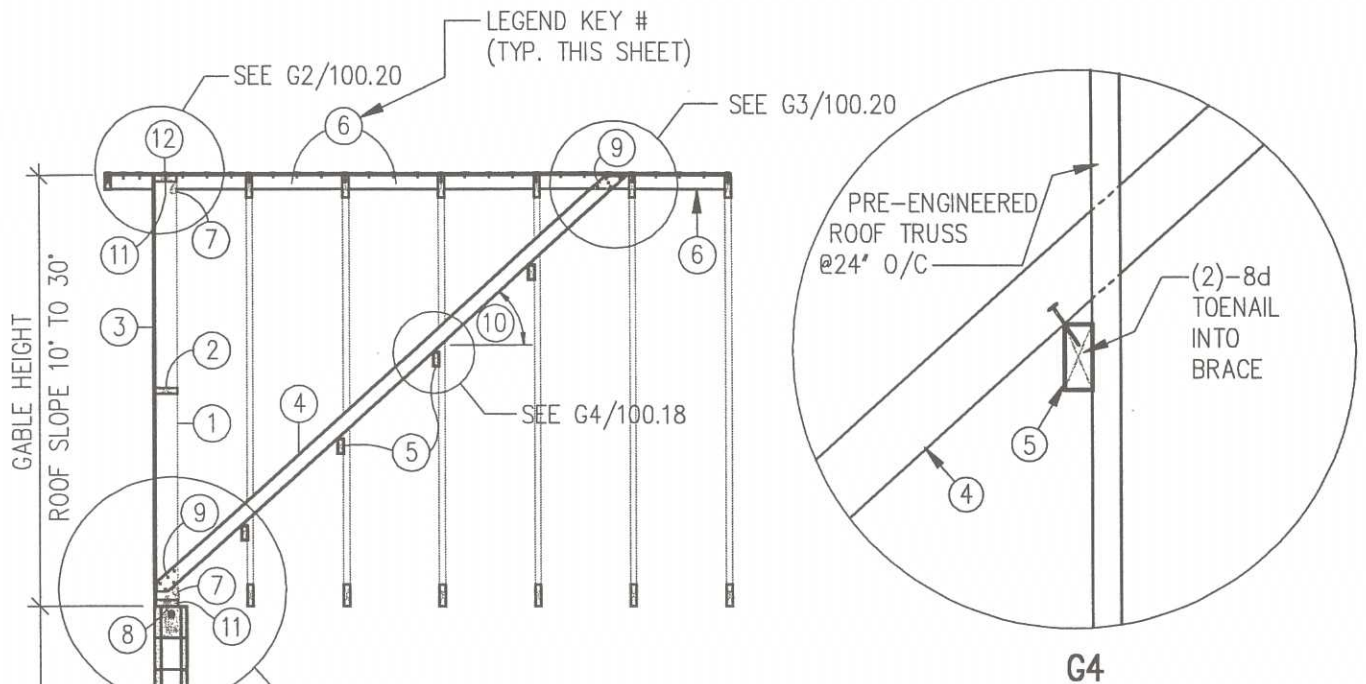

## LEGEND

- ① #2 2x6 @ 16" O/C
- ② FULLY BLOCKED EDGES
- ③ 7/16" MIN. RATED STRUCTURAL PANELS  
8d NAILS 6" O/C @ EDGES,  
12" O/C IN FIELD
- ④ DOUBLE 2x4 @ 32" O/C (1 EACH SIDE OF STUD)
- ⑤ 2x4 CONTINUOUS NAILED TO TRUSS WEBS.
- ⑥ 2x4 @ 32" O/C, ATTACH  
SHEATHING TO 2x4 @ 6" O/C WITH 8d NAILS
- ⑦ UPLIFT STRAP = 100 LBS @  
EACH STUD
- ⑧ 1/2"  $\phi$  BOLTS @ 48" O/C
- ⑨ (5) 8d NAILS FOR EACH 2x4  
OR 5/8"  $\phi$  THRU-BOLT
- ⑩ ANGLE MAX.= 45°
- ⑪ 2x6 P.T.
- ⑫ 8d NAILS @ 6" O/C

# ALTERNATE GABLE END DETAIL

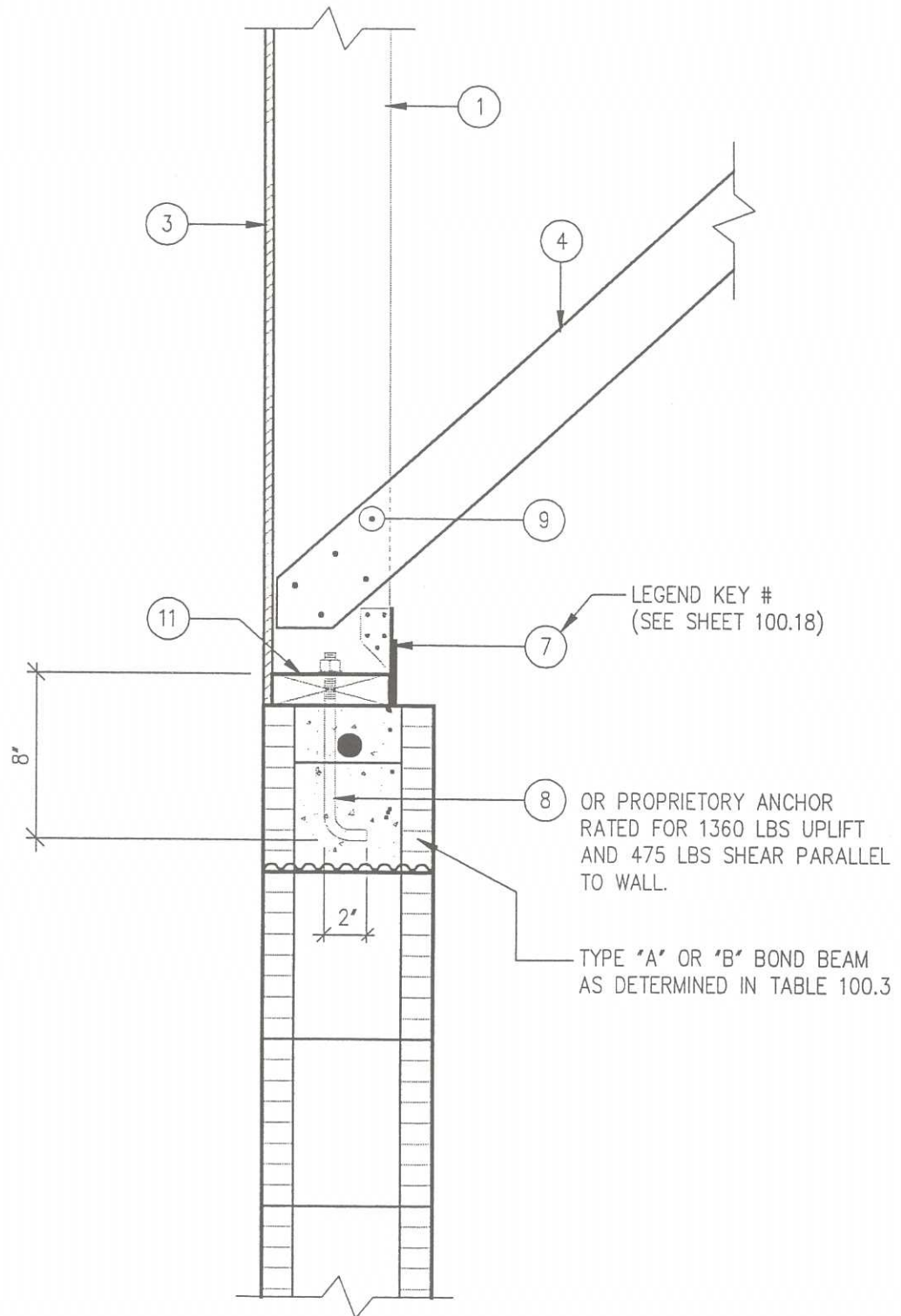

DETAIL G1

# ALTERNATE GABLE END DETAIL

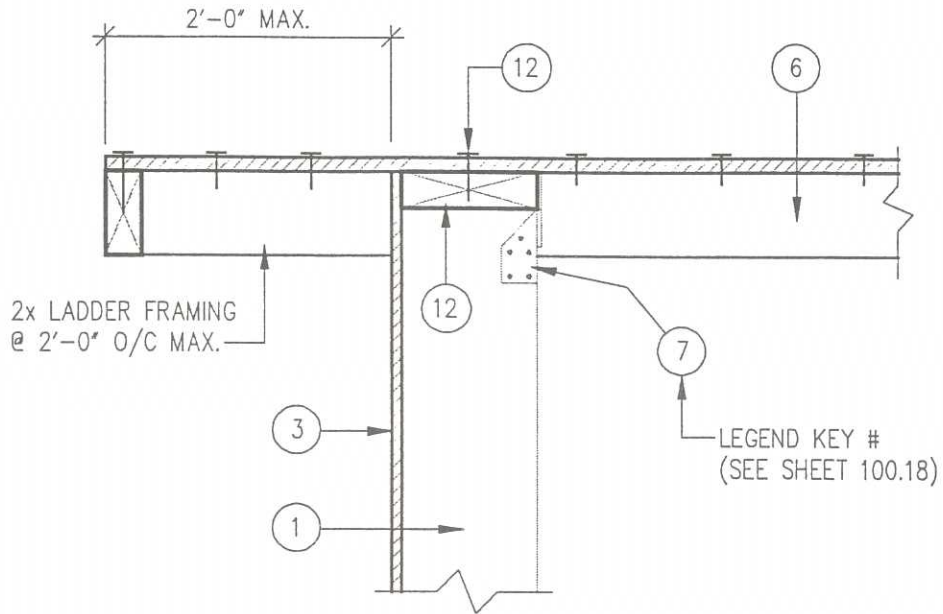

## DETAIL G2

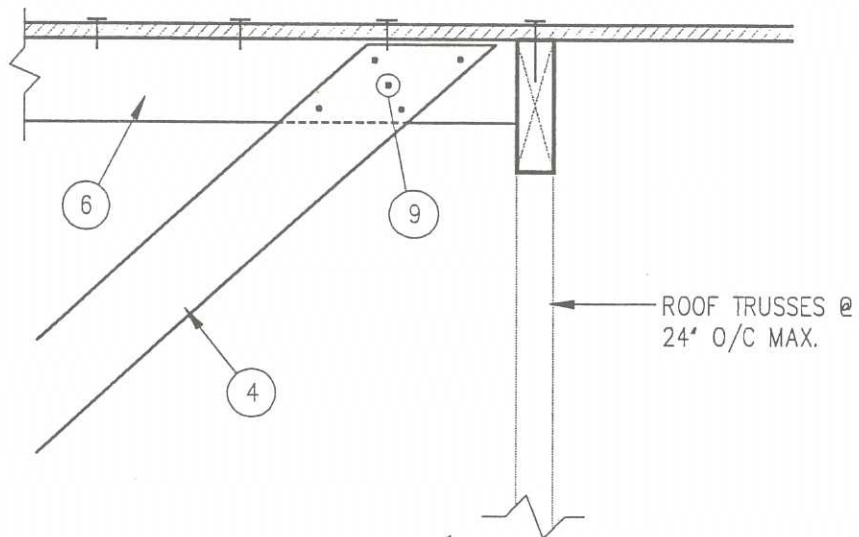

## DETAIL G3

# TABLE OF CONTENTS (110 mph)

## GUIDE TO CONCRETE MASONRY RESIDENTIAL CONSTRUCTION IN HIGH WIND AREAS 110 MPH DESIGN WIND SPEED VELOCITY

- 110.1 Table of Contents - 110 mph Design Wind Velocity
- 110.2 Vertical Reinforcement Details
- 110.3 Vertical Reinforcement Spacing
- 110.4 Gable Endwall Vertical Reinforcement
- 110.5 Shearwall Design Notes
- 110.6 Shearwall Proportioning Example
- 110.7 Shearwall Design Table
- 110.8 Lintel Types
- 110.9 Lintel Types - Continued
- 110.10 Lintel Schedule
- 110.11 Gable Endwall Details
- 110.12 Interior Bearing Wall Detail
- 110.13 Interior Bearing Wall Openings
- 110.14 Roof Truss Anchor
- 110.15 Entry Condition Details
- 110.16 Valley / Hip Detail
- 110.17 Roof Sheathing Attachment
- 110.18 Alternate Gable End Detail
- 110.19 Alternate Gable End Detail - Cont.
- 110.20 Alternate Gable End Detail - Cont.

# VERTICAL REINFORCEMENT DETAILS

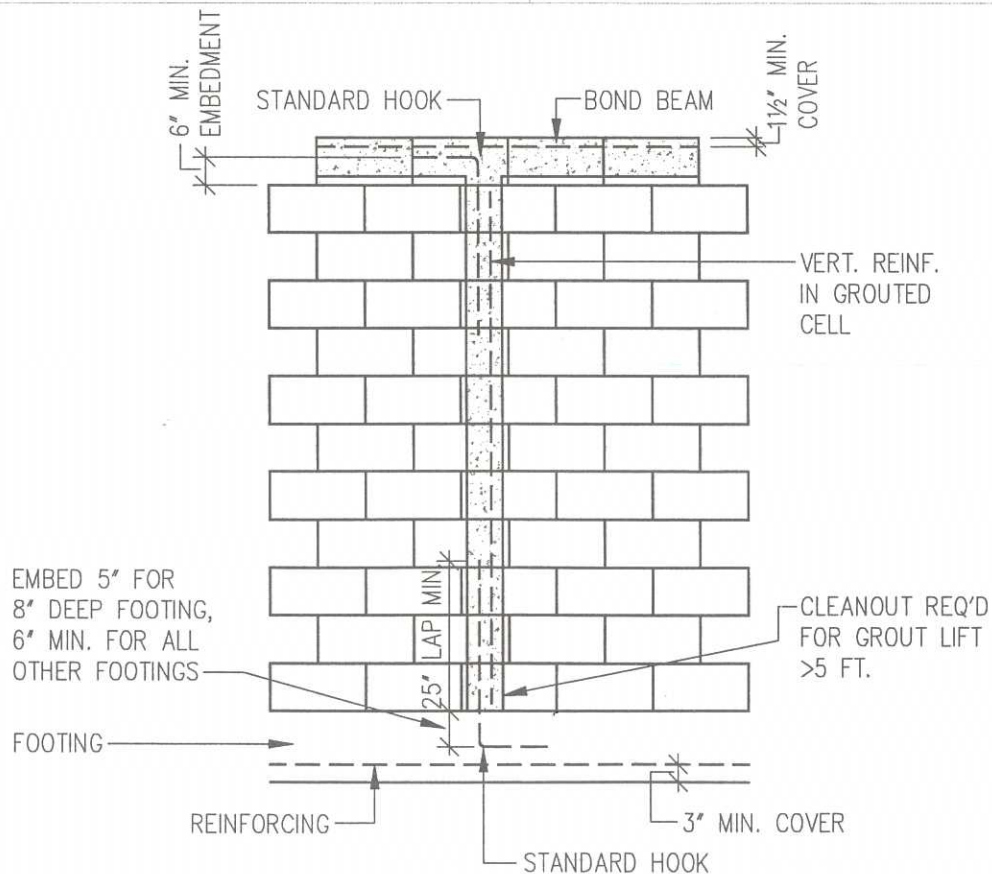
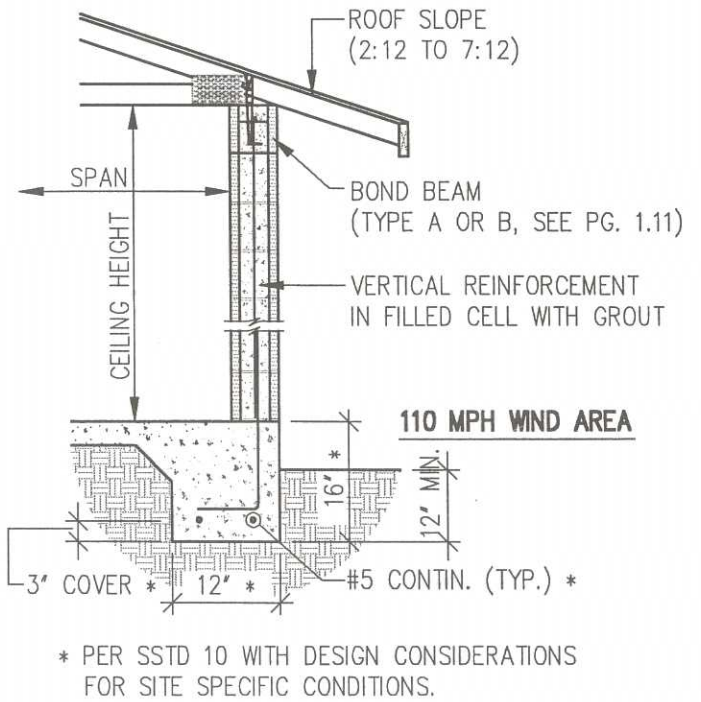
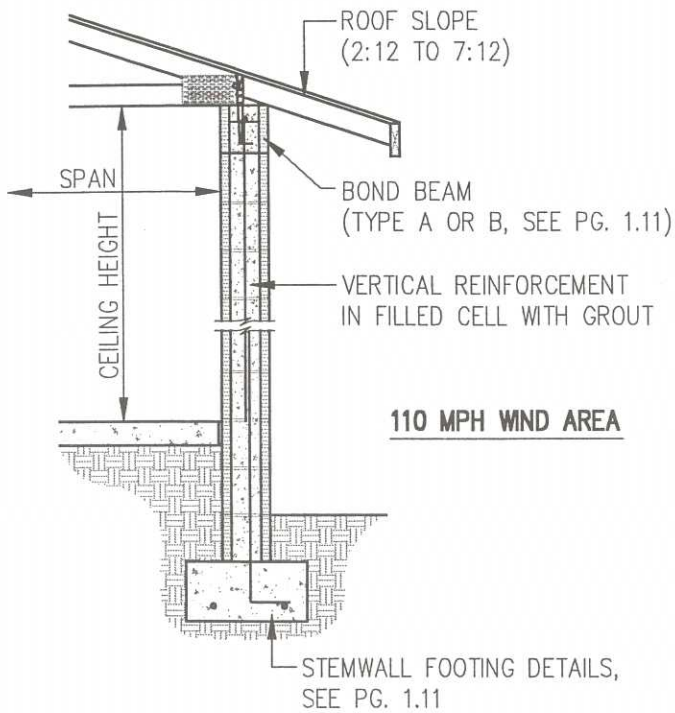

# VERTICAL REINFORCEMENT SPACING

<b>MAXIMUM SPACING OF #5 BAR IN FILLED CELLS</b>				
CEILING HEIGHT	BOND BEAM ⑤	SPAN 0'-20'	SPAN >20' TO 30'	SPAN >30' TO 40'
8'-0" OR LESS	A	10'-0"	9'-4"	8'-0"
	B	10'-0"	10'-0"	10'-0"
8'-8"	A	8'-8"	8'-8"	8'-0"
	B	8'-8"	8'-8"	8'-8"
9'-4"	A	7'-4"	7'-4"	7'-4"
	B	7'-4"	7'-4"	7'-4"
10'-0"	A	6'-8"	6'-8"	6'-8"
	B	6'-8"	6'-8"	6'-8"

NOTE:

1. PROVIDE ONE #5 BAR IN GROUTED CELL AT ALL WALL CORNERS AND INTERSECTIONS.
2. PROVIDE 1 #5 BAR IN GROUTED CELL AT EACH SIDE OF OPENINGS WIDER THAN 6'-0" AND AT EACH END OF SHEARWALL SEGMENTS. PROVIDE 2 #5 BARS ON EACH SIDE OF OPENINGS WIDER THAN 12'-0".
3. PROVIDE ONE #5 BAR IN GROUTED CELL AT ALL LOCATIONS WHERE GIRDERS OR GIRDER TRUSSES BEAR ON THE MASONRY WALL.
4. REDISTRIBUTE VERTICAL REINFORCEMENT ABOVE OPENINGS TO EACH SIDE OF OPENING. PROVIDE 1/2 OF THE REINFORCEMENT INTERRUPTED BY THE OPENING OR THE AMOUNT REQUIRED IN NOTE 2, WHICHEVER IS GREATER, ON EACH SIDE OF THE OPENING.
5. SEE PG. 1.11 FOR DESCRIPTION OF BOND BEAM TYPES 'A' AND 'B'.

# CONTINUOUS MASONRY GABLE END WALL VERTICAL REINFORCEMENT

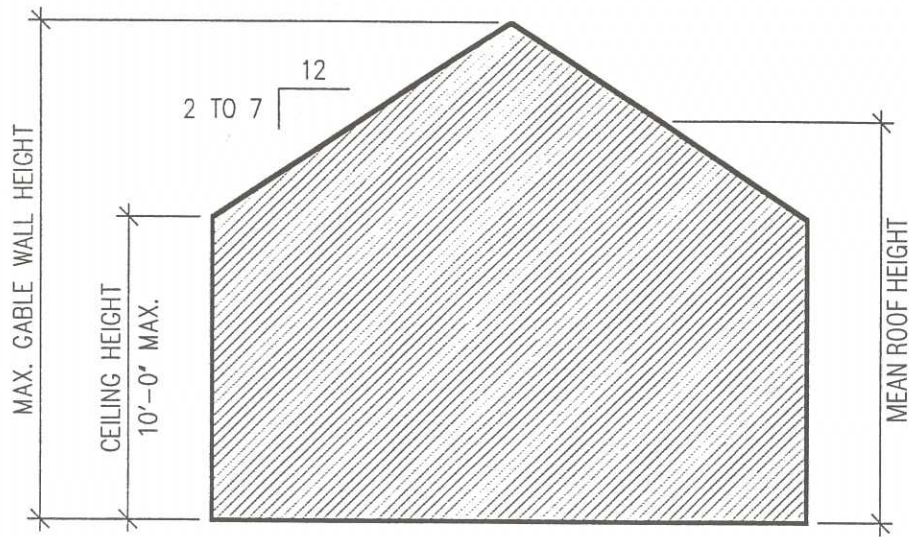

$$\text{MEAN ROOF HEIGHT} = \frac{\text{CEILING HEIGHT} + \text{MAX. GABLE HEIGHT}}{2}$$

TO DETERMINE THE VERTICAL SPACING REQUIRED FOR CONTINUOUS MASONRY GABLE WALLS, USE ONE OF THE FOLLOWING METHODS:

- METHOD 1.) DETERMINE THE MEAN ROOF HEIGHT OF THE GABLE END WALL AND USE THAT WALL HEIGHT IN THE TABLE BELOW TO OBTAIN THE VERTICAL REINFORCEMENT SPACING FOR THE ENTIRE WALL.
- METHOD 2.) DIVIDE THE GABLE WALL INTO SEGMENTS AND VARY THE VERTICAL SPACING BASED ON THE AVERAGE WALL HEIGHT IN EACH SEGMENT.

HEIGHT (EITHER BY METHOD 1 OR BY METHOD 2)	8' TO 10'	> 10' TO 13'	> 13' TO 16'	> 16' TO 19'	> 19' TO 22'
MAXIMUM SPACING OF 1#5 IN FILLED CELLS	6'-8'	3'-4'	2'-0'	1'-4'	0'-8'



## NOTES ON SHEARWALL LENGTH DESIGN

- 1.) MINIMUM SHEARWALL SEGMENT LENGTH SHALL BE 2'-0".  
FILLED CELL WITH 1#5 BAR REQUIRED AT EACH END OF SHEARWALL SEGMENT.
- 2.) PORTIONS OF WALLS WITH OPENINGS SHALL NOT BE CONSIDERED PART OF THE SHEARWALL LENGTH.
- 3.) THE CUMULATIVE SHEARWALL LENGTH FOR EACH SIDE OF THE BUILDING MUST BE EQUAL TO OR GREATER THAN THE TABULATED SHEARWALL LENGTH REQUIRED.

\* DOES NOT HAVE TO BE CONTINUOUS, AS LONG AS TOTAL LENGTH OF SEPARATE SEGMENTS MEETS THE SHEARWALL LENGTH REQUIREMENTS.

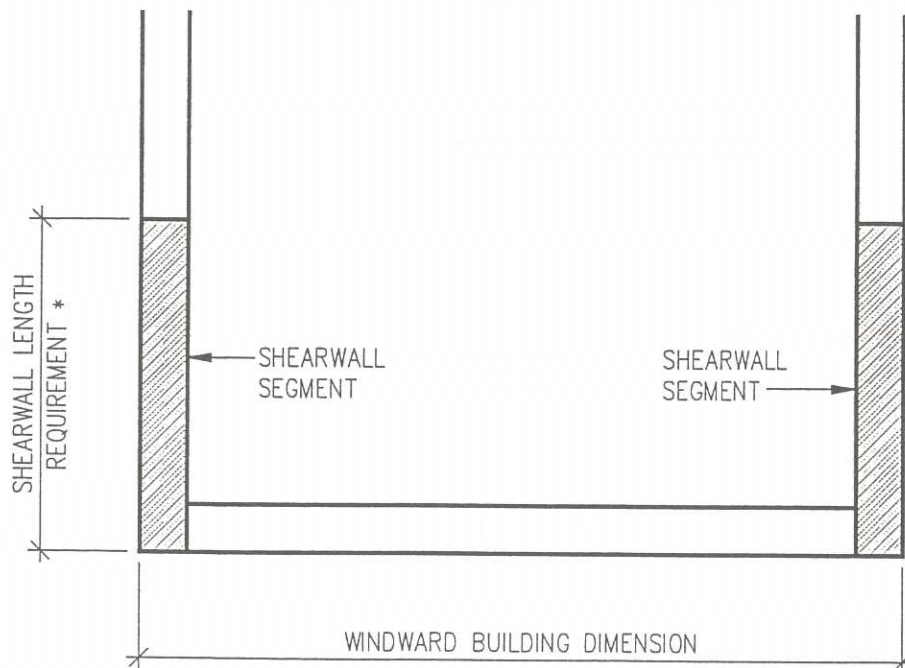

# SHEARWALL PROPORTIONING EXAMPLE

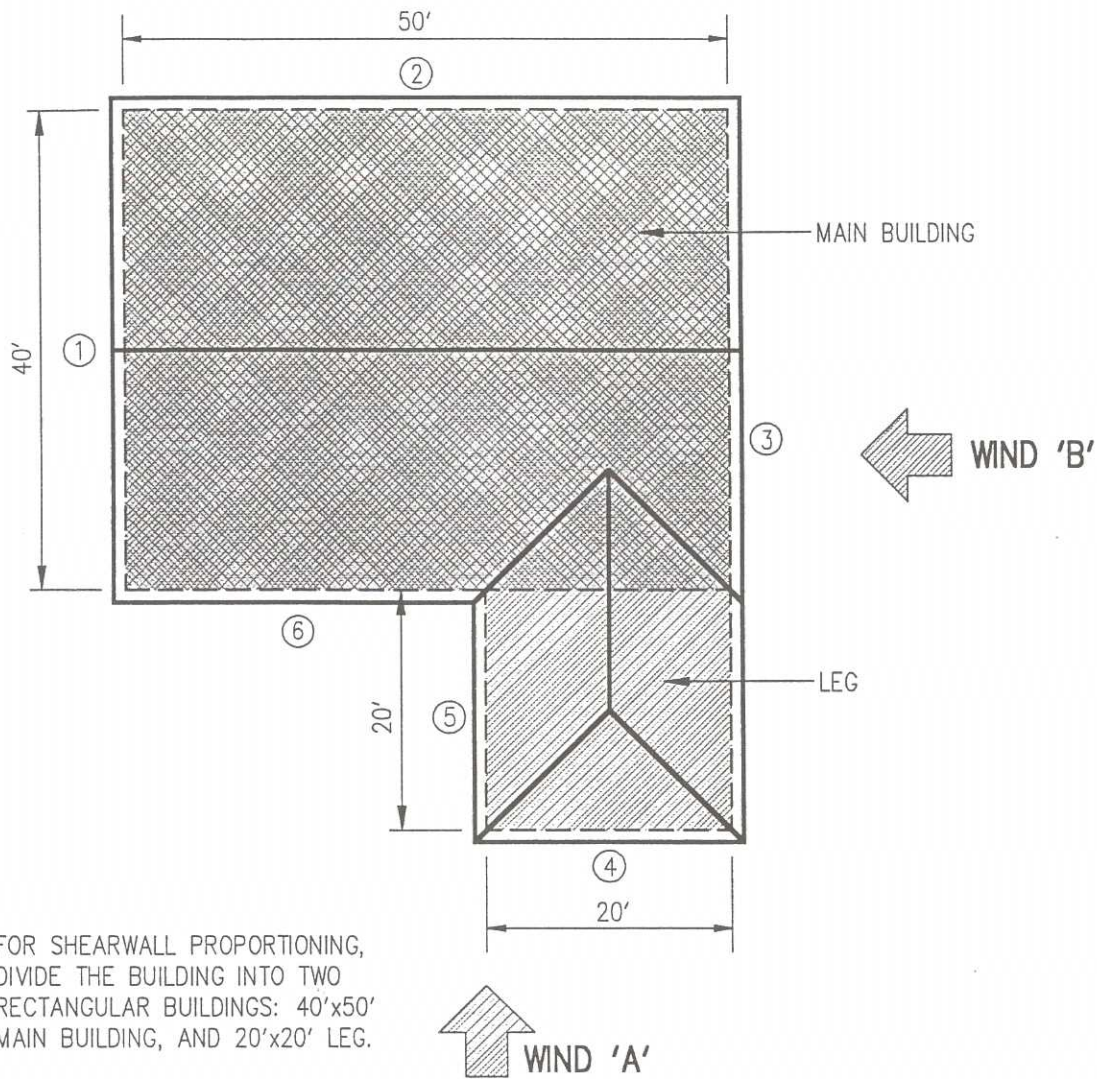

## WIND 'A'

TO DETERMINE THE AMOUNT OF SHEARWALL REQUIRED IN ①, ③ AND ⑤, THE "WINDWARD MAIN BUILDING DIMENSION" IS 50'. PER THE TABLE ON 110.4, THE REQUIRED SHEARWALL LENGTH IS 2'-4". THEREFORE PROVIDE A 2'-4" SEGMENT IN ① AND 2'-4" SEGMENT IN ③. ⑤ DOES NOT HAVE A SHEARWALL REQUIREMENT BECAUSE THE WINDWARD BUILDING AREA OF THE MAIN BUILDING WAS NOT INCREASED BY THE LEG.

## WIND 'B'

TO DETERMINE THE AMOUNT OF SHEARWALL REQUIRED IN ②, ④ AND ⑥, THE LENGTH REQUIRED IN ② AND THE MAIN BUILDING PORTION OF ⑥ IS BASED UPON 40' FOR A GABLE END. THE LENGTH REQUIRED FOR ④ AND THE LEG PORTION OF ⑥ IS BASED UPON 20'. THE SHEARWALL LENGTH IN ⑥ SHALL BE EQUAL TO THE SUM OF ② AND ④. FOR THIS EXAMPLE, ② REQUIRES 3'-0", ④ REQUIRES 0'-9" (2'-0" MIN.) AND ⑥ REQUIRES 3'-9" (3'-0" + 0'-9").

# SHEARWALL DESIGN TABLE

## 110 MPH WIND AREA

REQUIRED SHEARWALL LENGTH (2:12 TO 7:12 ROOF SLOPE)

WINDWARD BUILDING DIMENSION	SHEARWALL LENGTH REQUIRED (EACH SIDE) OF BUILDING (EXCEPT GABLE END WINDS)	SHEARWALL LENGTH REQUIRED (EACH SIDE) OF BUILDING PERPENDICULAR TO GABLE END
10' TO 20'	0'-9" *	0'-11" *
>20' TO 30'	0'-3" *	1'-11" *
>30' TO 40'	1'-9" *	3'-0"
>40' TO 50'	2'-4"	
>50' TO 60'	2'-10"	
>60' TO 70'	3'-4"	
>70' TO 80'	3'-10"	

\* 2'-0" MINIMUM SHEARWALL SEGMENT LENGTH

NOTE: MAXIMUM SHEARWALL PIER HEIGHT= 6'-0" FOR 2'-0" LENGTH. A MAXIMUM SHEARWALL PIER HEIGHT OF 8'-8" IS ALLOWED FOR SHEARWALL LENGTHS OF 2'-8" OR GREATER.

# LINTEL TYPES



'A2'

8x8 MASONRY LINTEL W/1#5 BOTTOM  
FILLED SOLID WITH GROUT

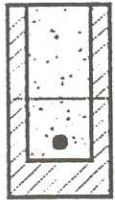

'B2'

8x16 MASONRY LINTEL W/1#5 BOTTOM  
FILLED SOLID WITH GROUT

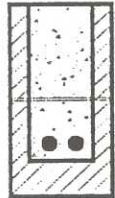

'B3'

8x16 MASONRY LINTEL W/2#5 BOTTOM  
FILLED SOLID WITH GROUT

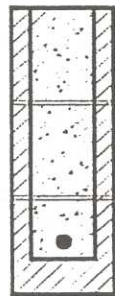

'C'

8x24 MASONRY LINTEL W/1#5 BOTTOM  
FILLED SOLID WITH GROUT



'C2'

8x24 MASONRY LINTEL W/2#5 BOTTOM  
FILLED SOLID WITH GROUT



'D'

8x32 MASONRY LINTEL W/2#5 BOTTOM  
FILLED SOLID WITH GROUT



'D2'







8x32 MASONRY LINTEL W/3#5 BOTTOM  
FILLED SOLID WITH GROUT

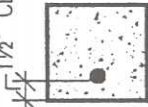

'E'

8x40 MASONRY LINTEL W/3#5 BOTTOM  
FILLED SOLID WITH GROUT

# LINTEL TYPES

<p>1 1/2" CLEAR (TYP.)</p>  <p>'F'</p> <p>8x8 CAST IN PLACE CONCRETE BEAM (2500 PSI) WITH 1#5 BOTTOM</p>	<p>1 1/2" CLEAR (TYPICAL)</p>  <p>'K'</p> <p>2#5 #3 STIRRUPS @7" O/C 2#5</p> <p>8x16 CAST IN PLACE CONCRETE BEAM (2500 PSI)</p>
 <p>'G'</p> <p>8x16 CAST IN PLACE CONCRETE BEAM (2500 PSI) WITH 2#5 BOTTOM</p>	 <p>'L'</p> <p>2#5 #3 STIRRUPS @11" O/C 2#6</p> <p>8x24 CAST IN PLACE CONCRETE BEAM (2500 PSI)</p>
 <p>'H'</p> <p>8x24 CAST IN PLACE CONCRETE BEAM (2500 PSI) WITH 2#6 BOTTOM</p>	 <p>'M'</p> <p>2#5 #3 STIRRUPS @15" O/C 4#6</p> <p>8x32 CAST IN PLACE CONCRETE BEAM (2500 PSI)</p>

# LINTEL SCHEDULE

LINTEL SCHEDULE				
MAX. CLEAR OPENING WIDTH	ROOF TRUSS SPAN	PRECAST LINTEL ALLOWABLE LOAD (PLF) ③	MASONRY LINTEL	CAST IN PLACE BEAMS
UP TO 3'-0"	0' TO 20'	650	A2	F
	>20' TO 30'	875	A2	G
	>30' TO 40'	1,100	A2	G
>3'-0" TO 6'-0"	0' TO 20'	650	B2	G
	>20' TO 30'	875	B2	G
	>30' TO 40'	1,100	B2	H OR K
>6'-0" TO 9'-0"	0' TO 20'	650	B3	H OR K
	>20' TO 30'	875	C	H OR K
	>30' TO 40'	1,100	C2	J OR K
>9'-0" TO 12'-0"	0' TO 20'	650	C2	H OR K
	>20' TO 30'	875	C2	J OR L
	>30' TO 40'	1,100	D	L
>12'-0" TO 15'-0"	0' TO 20'	650	D	J OR L
	>20' TO 30'	875	D	L
	>30' TO 40'	1,100	D2	M
>15'-0" TO 18'-0"	0' TO 20'	650	D	L
	>20' TO 30'	875	E	M
	>30' TO 40'	1,100	E	M

NOTE:

1. MUST MAINTAIN CONTINUITY OF BOND BEAM AT TOP OF WALL.
2. IF MASONRY OPENING EXCEEDS SCHEDULED VERTICAL REINFORCEMENT SPACING, THEN LINTEL, BOND BEAM AND WALL ABOVE OPENING SHALL BE FILLED SOLID OVER OPENING WIDTH.
3. RATED CAPACITY OF PRECAST LINTEL BY ITSELF OR THROUGH COMPOSITE ACTION WITH OTHER ELEMENTS.

# GABLE ENDWALL DETAILS

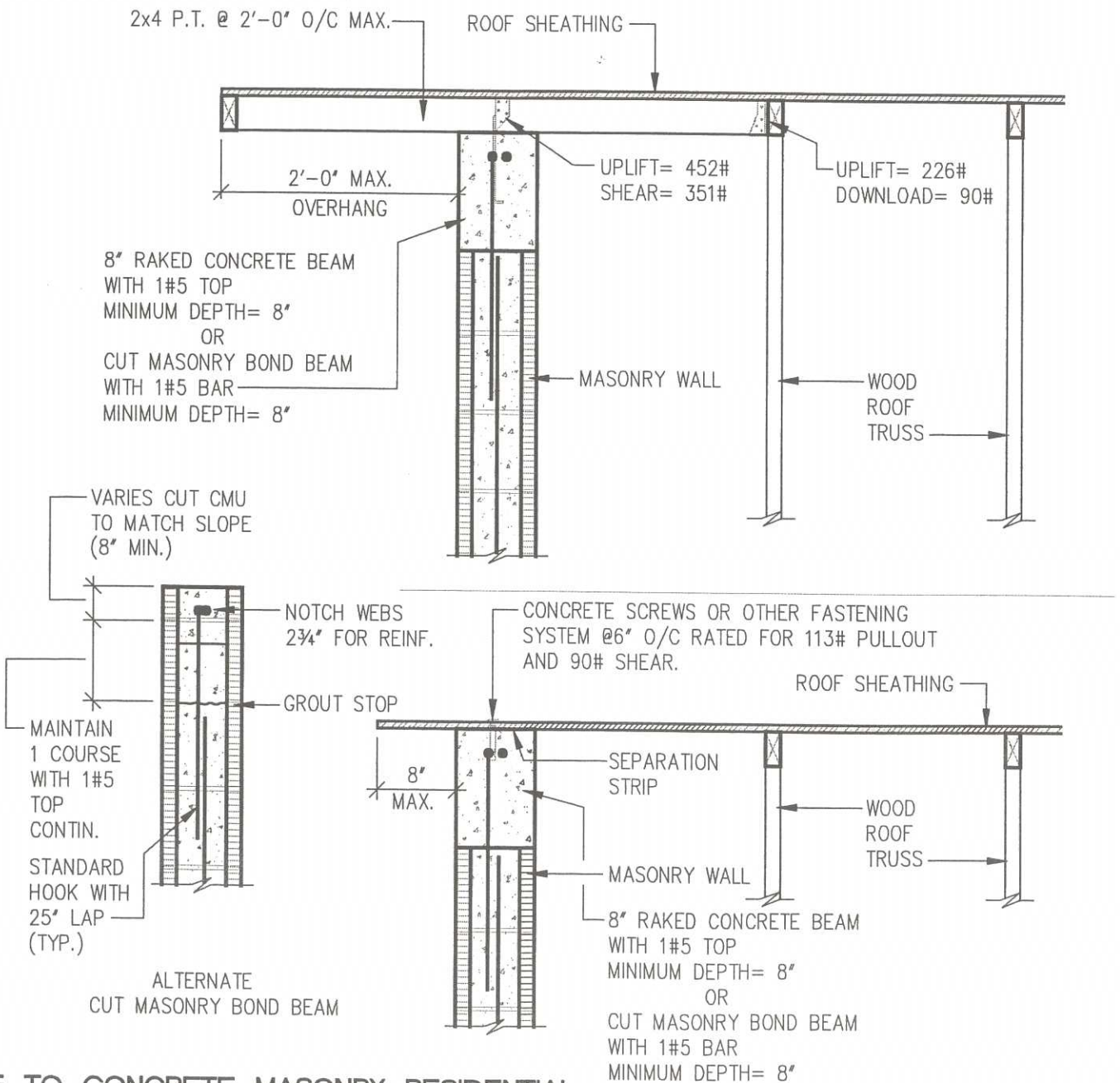
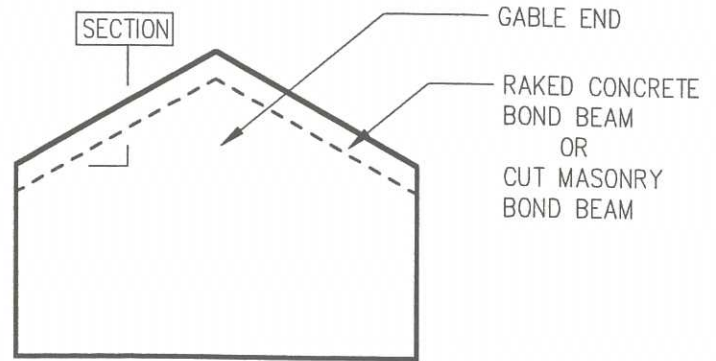

# INTERIOR BEARING WALL DETAIL

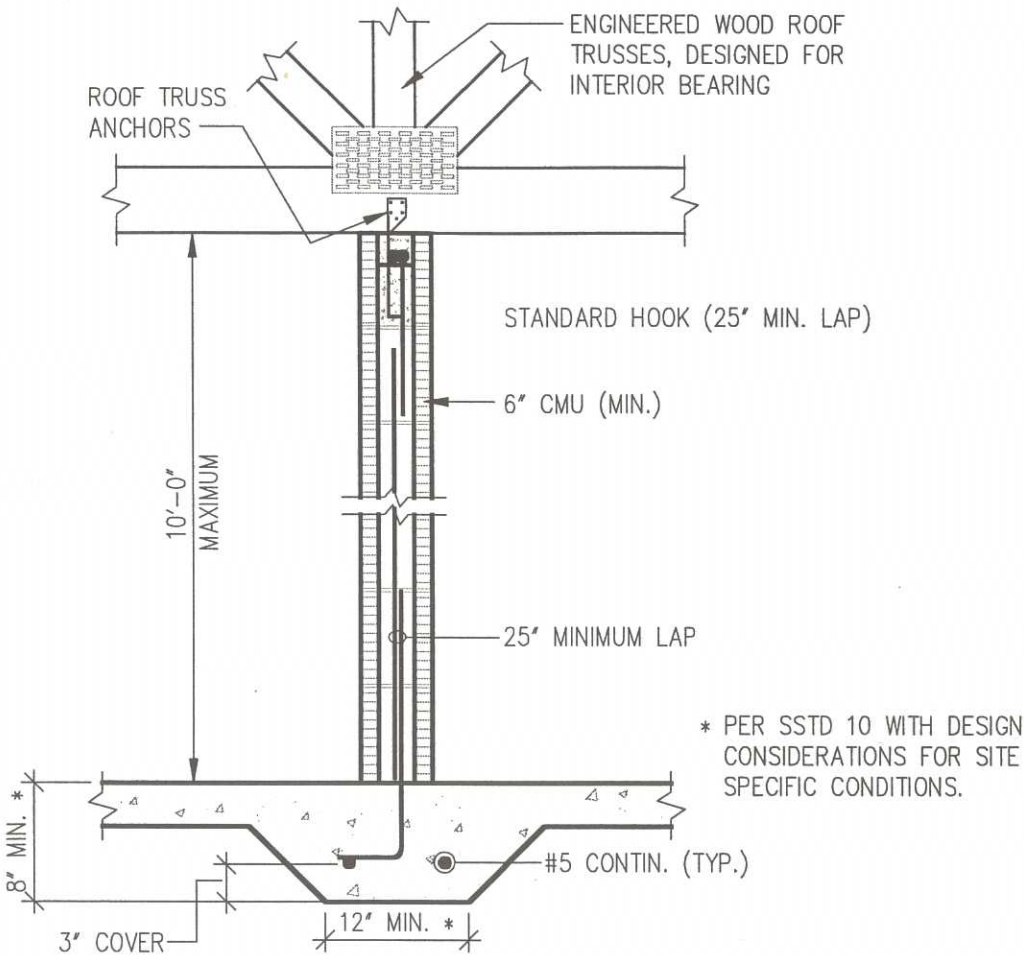

SPAN	ROOF TRUSS ANCHOR NET UPLIFT (LBS) (TRUSSES @ 24')		MAX. SPACING OF #5 BAR IN FILLED CELL	
	INTERIOR ZONE	END ZONE (TRUSSES 8' OR CLOSER TO OUTSIDE OF ENDWALL)	BOND BEAM 'A' (6x8)	BOND BEAM 'B' (6x16)
10'	134	219	11'-4"	22'-8"
20'	268	438	8'-8"	16'-8"
30'	402	657	6'-8"	14'-0"
40'	536	876	6'-0"	12'-8"
50'	670	1095	4'-8"	12'-0"
60'	804	1314	3'-4"	10'-0"
70'	938	1533	3'-4"	8'-8"
80'	1072	1752	2'-8"	7'-4"

**NOTE:**

1. PROVIDE ONE #5 BAR IN GROUTED CELL AT CORNERS AND INTERSECTIONS.
2. PROVIDE 1 #5 BAR IN GROUTED CELL AT EACH SIDE OF OPENINGS WIDER THAN 6'-0" AND 2 #5 BARS ON EACH SIDE OF OPENINGS WIDER THAN 12'-0".
3. PROVIDE ONE #5 BAR IN GROUTED CELL AT ALL LOCATIONS WHERE GIRDERS OR GIRDER TRUSSES BEAR ON THE MASONRY WALL.
4. INTERIOR BEARING WALLS MAY BE CONSTRUCTED OF ALTERNATE MATERIALS IN ACCORDANCE WITH ACCEPTED STANDARDS.



# INTERIOR BEARING WALL OPENINGS

LINTEL SCHEDULE FOR 6' CMU INTERIOR WALLS				
TRUSS SPAN ⑤	OPENING WIDTH	PRECAST LINTEL ALLOWABLE LOAD (PLF)	MASONRY LINTEL	CAST IN PLACE BEAMS ④
0' TO 20'	0' TO 6' > 6' TO 9' > 6' TO 12'	617	B2 B3 C2	G H OR K J OR L
>20' TO 30'	0' TO 6' > 6' TO 9' > 6' TO 12'	842	B2 C D	H OR K J OR K L
>30' TO 40'	0' TO 6' > 6' TO 9' > 6' TO 12'	1067	C D E	H OR K J OR K L
>40' TO 50'	0' TO 6' > 6' TO 9' > 6' TO 12'	1292	C D E	J OR K K L
>50' TO 60'	0' TO 6' > 6' TO 9' > 6' TO 12'	1517	C E —	J OR K L L
>60' TO 70'	0' TO 6' > 6' TO 9' > 6' TO 12'	1742	D E —	K L M
>70' TO 80'	0' TO 6' > 6' TO 9' > 6' TO 12'	1967	D — —	K L M

**NOTE:**

- 1.) MUST MAINTAIN CONTINUITY OF BOND BEAM.
- 2.) LINTEL TYPES REFERENCED ARE SIMILAR TO 8' LINTELS (110.8) EXCEPT THE BEAM WIDTH IS 6".
- 3.) IF MASONRY OPENING EXCEEDS SCHEDULED VERTICAL REINFORCEMENT SPACING, THEN LINTEL, BOND BEAM AND WALL ABOVE OPENING SHALL BE FILLED SOLID OVER OPENING WIDTH.
- 4.) IF THE CAST IN PLACE BEAM REQUIRES STIRRUPS, THAN USE 8' CMU INTERIOR WALL.
- 5.) THE TRUSS SPAN EQUALS THE SUM OF THE SPANS ON BOTH SIDES OF THE INTERIOR WALL.

# ROOF TRUSS ANCHOR

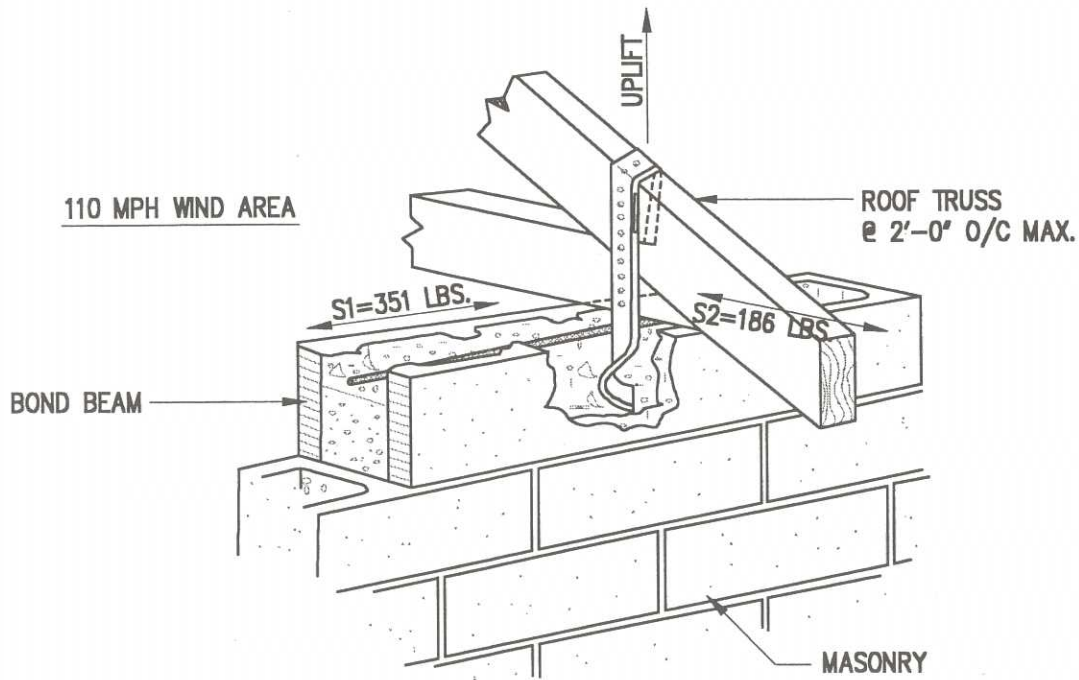

TRUSS ANCHOR LOAD SCHEDULE, LBS.		
ROOF TRUSS SPAN	NET UPLIFT INTERIOR ZONE	NET UPLIFT END ZONE (WITHIN 8' OF CORNER)
0' TO 20'	403	596
>20' TO 30'	550	840
>30' TO 40'	698	1084

- NOTES: 1. FOR NO.1 HIP, CORNER JACKS AND END JACKS OF HIP ROOFS, USE TRUSS MANUFACTURERS LOADS OR SSTD 10. FOR GIRDER TRUSSES, USE TRUSS MANUFACTURERS LOADS.  
 2. FOR END JACKS, THE SIDEWALL LOADS AS DETERMINED BY THIS DOCUMENT MAY ALSO BE USED.

# ENTRY CONDITION DETAILS

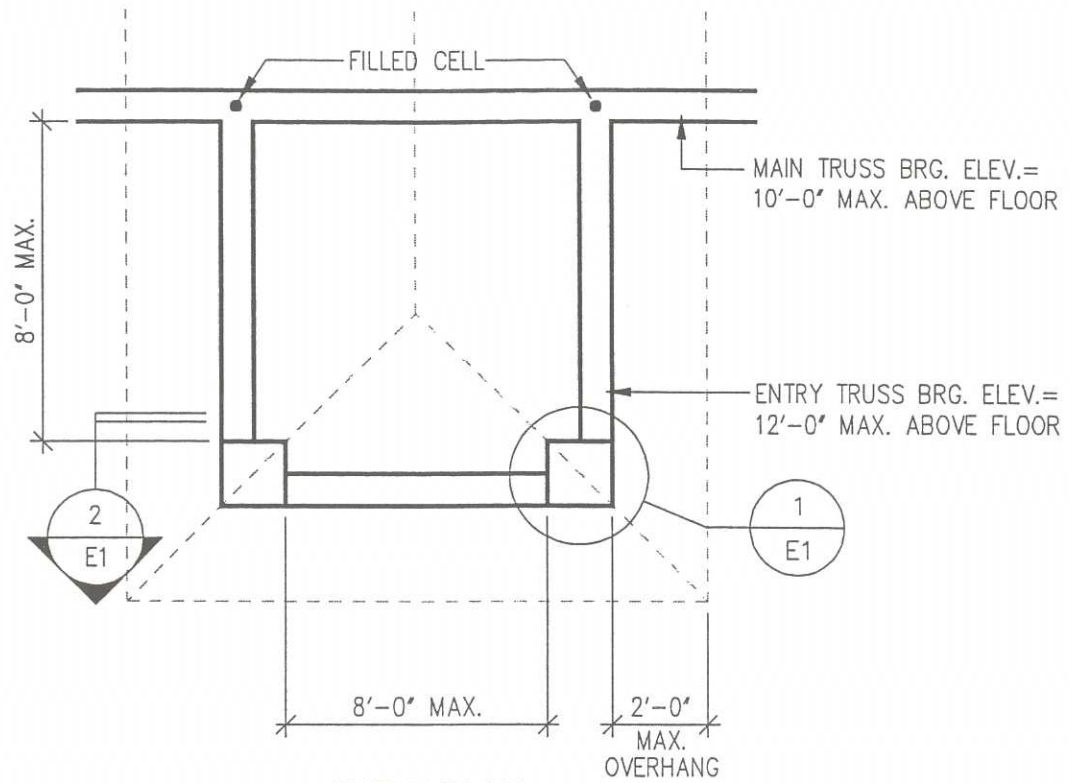

ENTRY PLAN

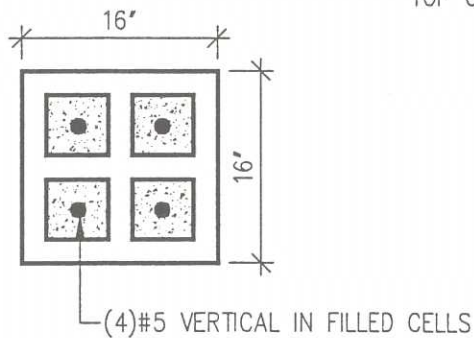

1  
E1 MASONRY POST AT ENTRY

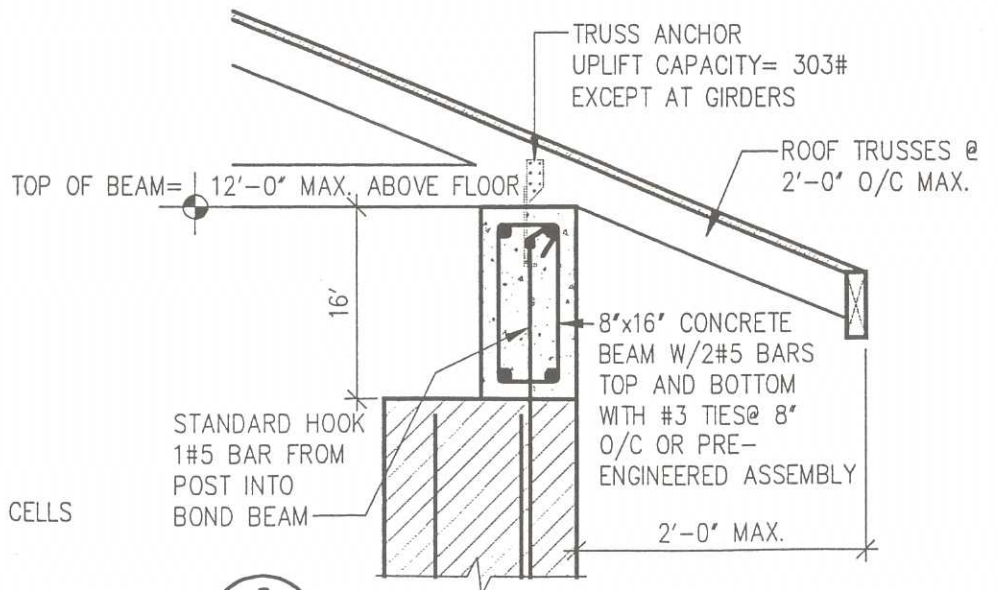

2  
E1 PERIMETER BEAM FOR ENTRY

# VALLEY \ HIP DETAIL

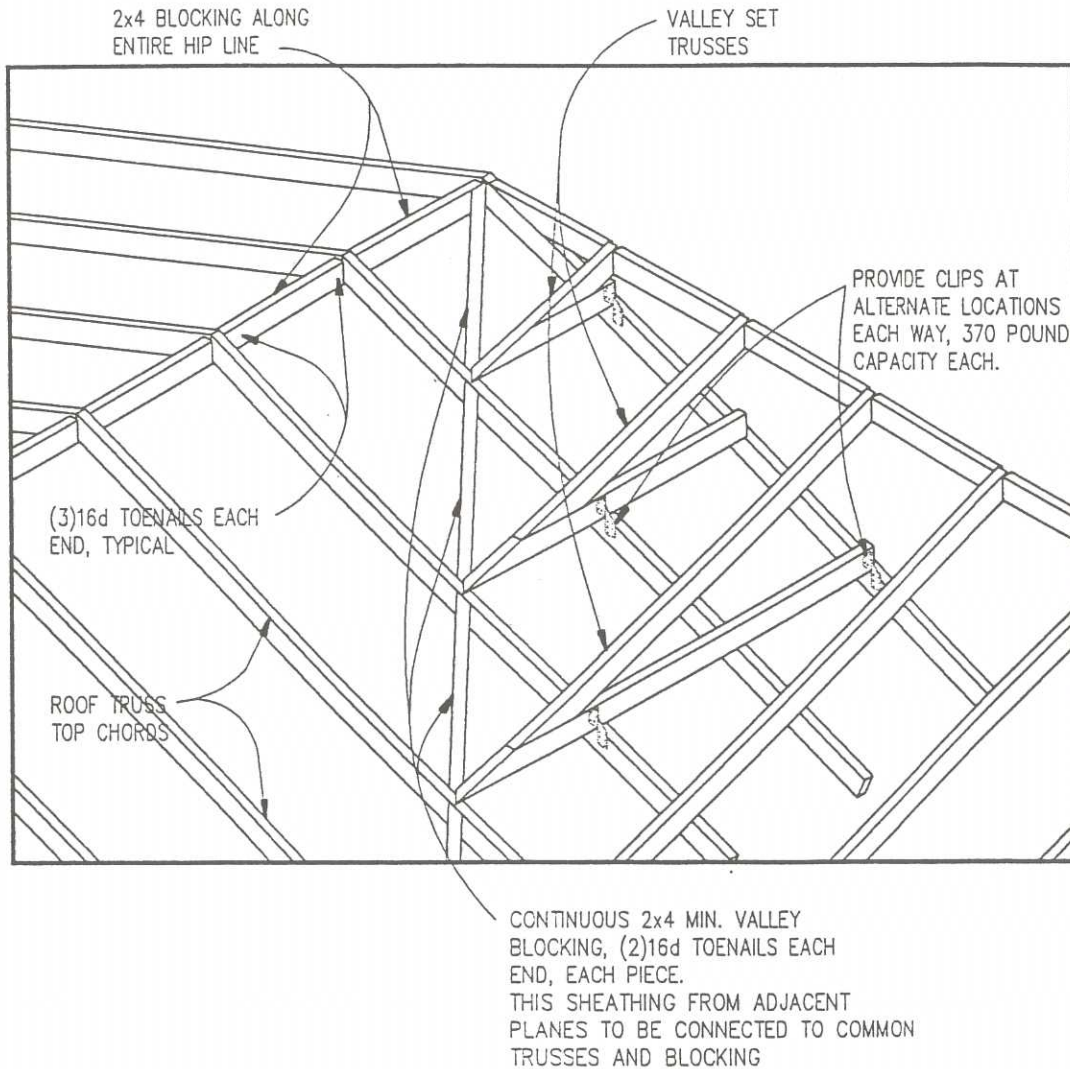

NOTE: SHEATHING MAY BE PROVIDED BETWEEN MAIN ROOF TRUSSES AND VALLEY SET TRUSSES.

THIS DETAIL APPLIES TO PRIMARY ROOF PLANES

# ROOF SHEATHING ATTACHMENT

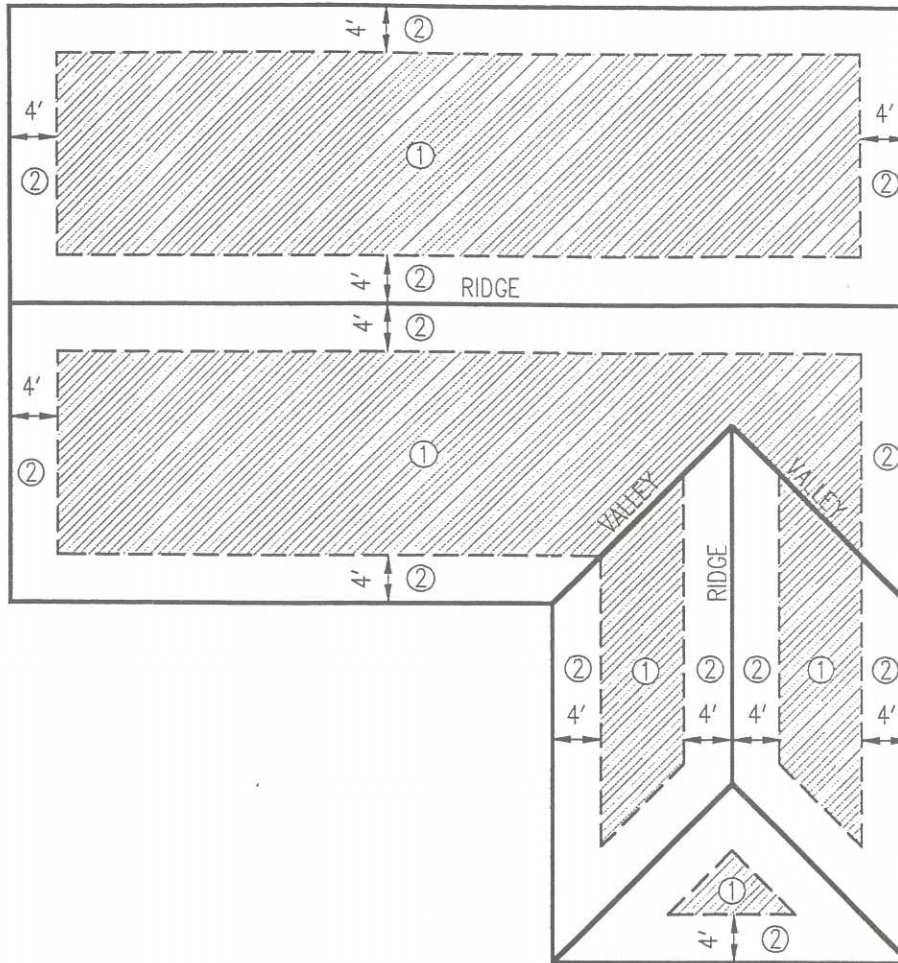

## SHEATHING NOTES:

ROOF SHEATHING TO BE WOOD STRUCTURAL PANEL RATED SHEATHING OR BETTER, EXPOSURE 1.

ROOF SHEATHING SHALL BE 7/16" THICKNESS OR GREATER.

ROOF TRUSSES @ 24" O/C MAXIMUM.

TRUSS TOP CHORDS SHALL HAVE A SPECIFIC GRAVITY OF G=0.46 OR GREATER.

### NAILING PATTERN:

ZONE	SPACING
①	12" O/C MAX. IN FIELD, 6" O/C MAX PANEL EDGES.
②	6" O/C MAX. IN FIELD & AT EDGES.

NAILS SHALL BE: 8d COMMON FOR 7/16" & 15/32",  
10d COMMON FOR 1/2", 19/32", AND 5/8".

SEE ALSO SHEETS 110.7, 110.11, 110.18, 110.19, AND 110.20. FOR GABLE END REQUIREMENTS

# ALTERNATE GABLE END DETAIL

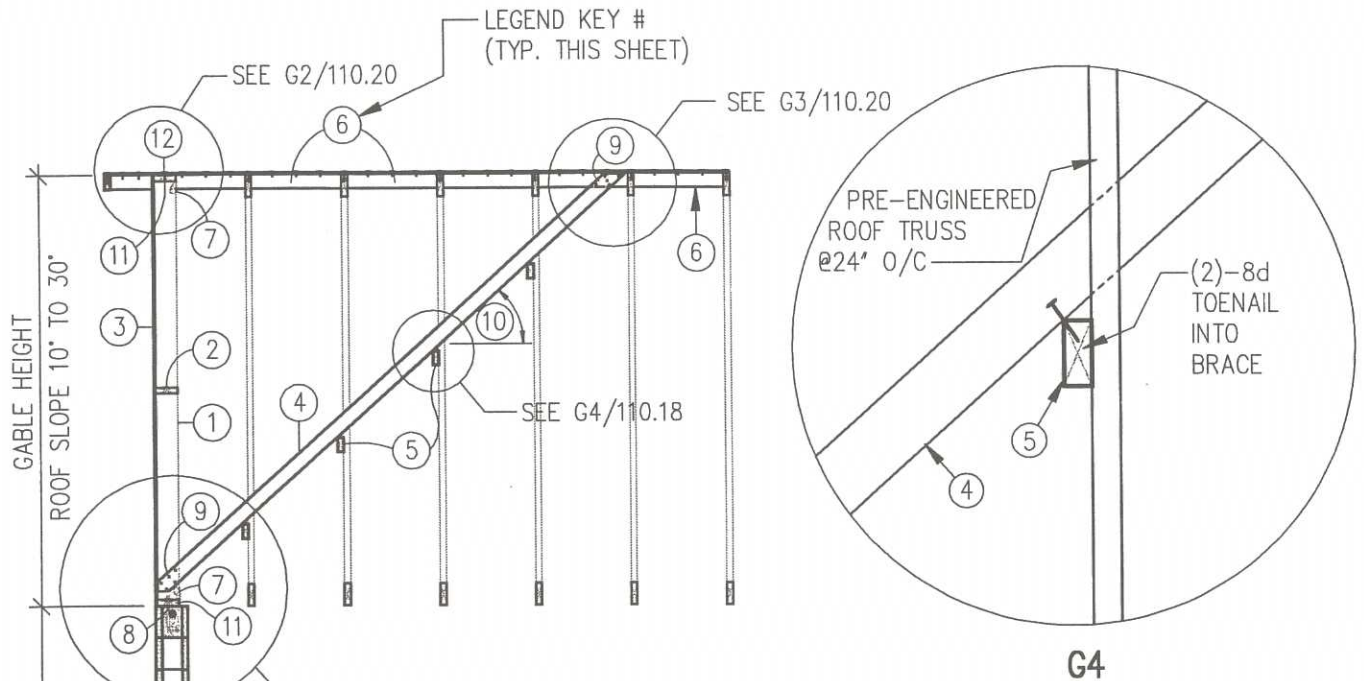

## LEGEND

- ① #2 2x6 @ 16" O/C
- ② FULLY BLOCKED EDGES
- ③ 7/16" MIN. RATED STRUCTURAL PANELS  
8d NAILS 6" O/C @ EDGES,  
12" O/C IN FIELD
- ④ DOUBLE 2x4 @ 32" O/C (1 EACH SIDE OF STUD)
- ⑤ 2x4 CONTINUOUS NAILED TO TRUSS WEBS.
- ⑥ 2x4 @ 32" O/C, ATTACH  
SHEATHING TO 2x4 @ 6" O/C WITH 8d NAILS
- ⑦ UPLIFT STRAP = 100 LBS @  
EACH STUD
- ⑧ 1/2"  $\phi$  BOLTS @ 48" O/C
- ⑨ (5) 8d NAILS FOR EACH 2x4  
OR 5/8"  $\phi$  THRU-BOLT
- ⑩ ANGLE MAX. = 45°
- ⑪ 2x6 P.T.
- ⑫ 8d NAILS @ 6" O/C

# ALTERNATE GABLE END DETAIL

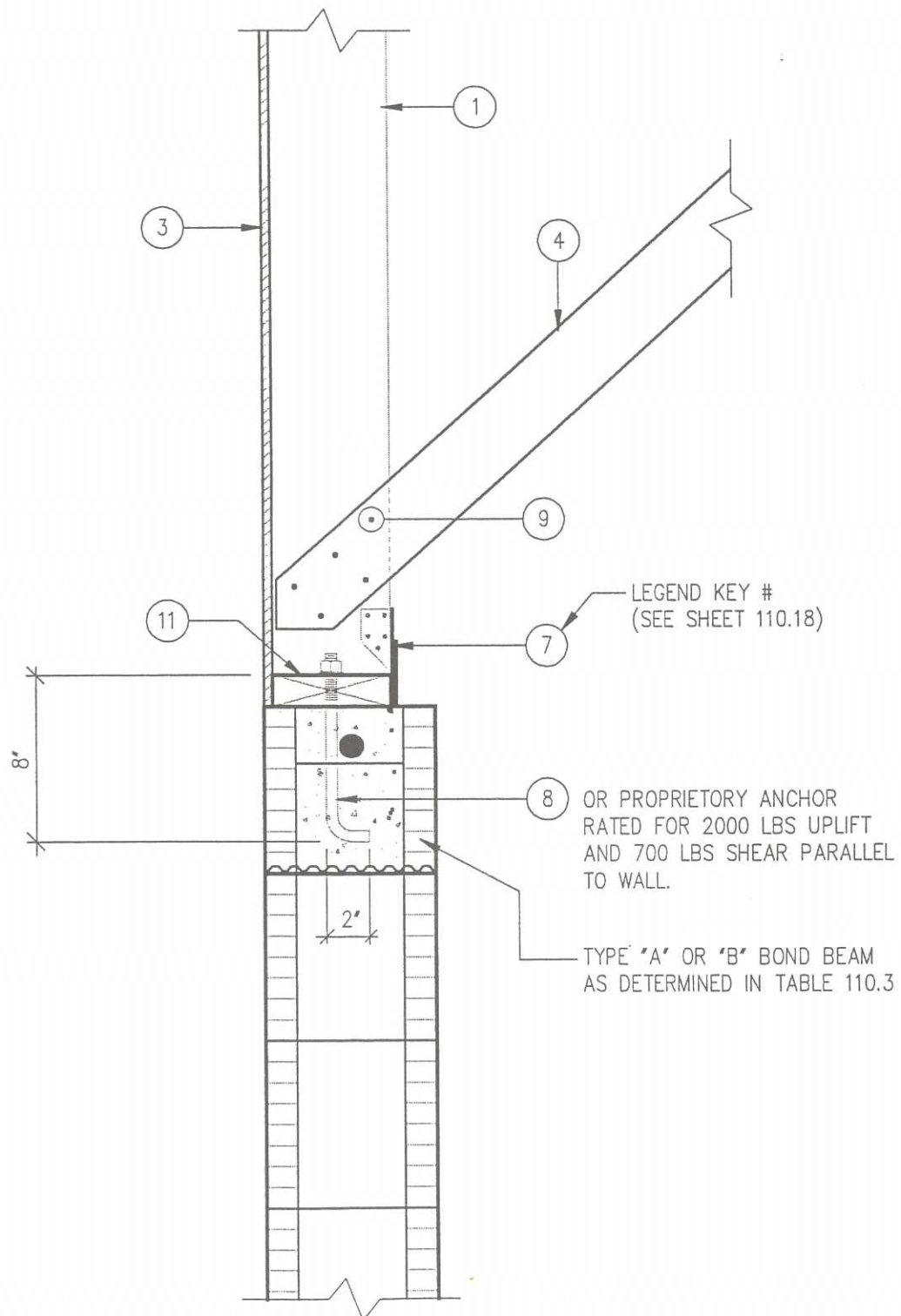

DETAIL G1

# ALTERNATE GABLE END DETAIL

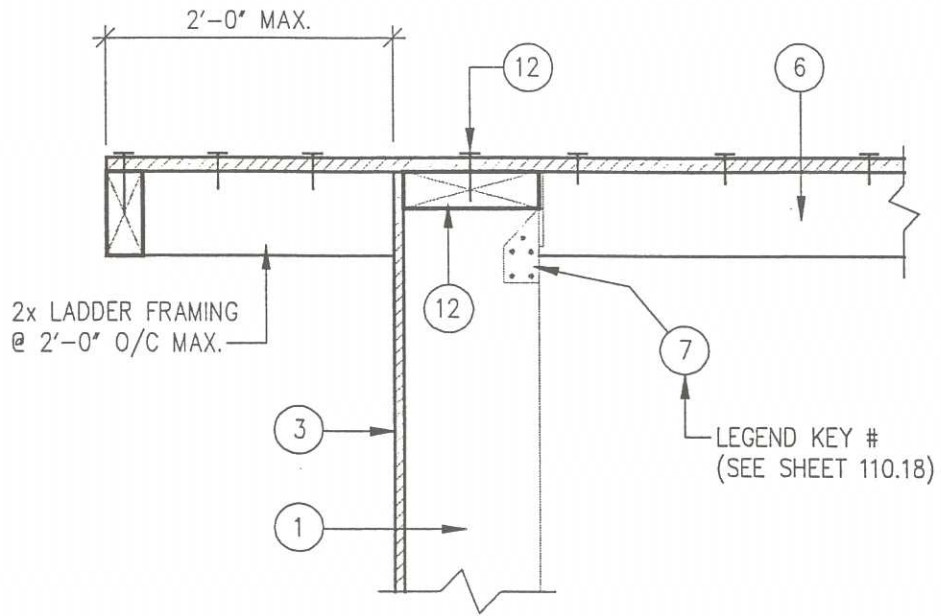

## DETAIL G2

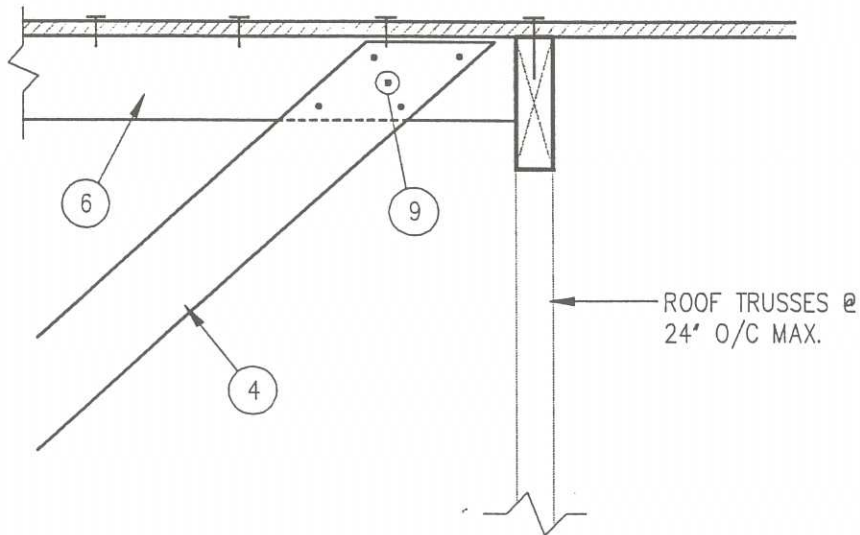

## DETAIL G3





5420 Old Orchard Road  
Skokie, Illinois 60077-1083  
Phone: 847-966-6200  
Fax: 847-966-9781  
<http://www.portcement.org>



2302 Horse Pen Road  
Herndon, Virginia 22071-3499  
Phone: 703-713-1900  
Fax: 703-713-1910  
<http://www.ncma.org>



FLORIDA CONCRETE & PRODUCTS ASSOCIATION, INC.

3030 Dade Avenue, Orlando, FL 32804-4014

Tel: 407-895-9333 • Fax: 407-895-3733 • Watts: 800-342-0080

<http://www.fcpa.org>